



**A Summary of  
Selected Technology  
Achievements in  
The Islamic Republic of Iran**

In the Name of God



**A Summary of Selected Technology Achievements in  
The Islamic Republic of Iran**

Book Title:  
A Summary of Selected Technology Achievements in  
The Islamic Republic of Iran

Publication Date: 2014  
Number of Pages: 115

# Contents

## Iran at a Glance

### 1. Iran's Science & Technology Status

1.1 Introduction.....	3
1.2 Science and Technology Orientation.....	3
1.3 Iran's Science & Technology Statistics.....	4
1.4 Iran's Science & Technology Publications.....	9

### 2. Biotechnology

2.1 Introduction.....	13
2.2 Current Biotechnology Status in Iran.....	13
2.3 Iranian Biotechnology Research and Development Priorities.....	14
2.4 Iranian Biotechnology Centers.....	14
2.5 Medical Biotechnology.....	15
2.5.1 Pasteur Institute of Iran.....	15
2.5.2 Major Achievements in Medical Biotechnology.....	16
2.6 Medical Equipment.....	23
2.6.1 Institute for Advanced Medical Technologies (IAMT).....	23
2.6.2 Major Achievements in Medical Equipment.....	25
2.7 Agricultural Biotechnology.....	32
2.7.1 Agricultural Biotechnology Research Institute of Iran (ABRII).....	32
2.7.2 National Institute of Genetic Engineering and Biotechnology (NIGEB).....	33
2.7.3 Major Agricultural Biotechnology Products.....	33
2.8 Some Other Iranian Biotechnology Achievements.....	37

### 3. Nanotechnology

3.1 Introduction.....	39
3.2 Iran Main Nanotechnology Actors.....	39
3.3 Current Nanotechnology Status in Iran.....	43
3.4 Nanotechnology Priorities.....	47
3.5 Iranian Nanotechnology Companies.....	47

<b>4. Energy</b>	
Part One: Conventional Energies (Oil & Gas)	61
4.1.1 Introduction	61
4.1.2 Current Conventional Energies (Oil & Gas) Status in Iran	61
4.1.3 Research Institute of Petroleum Industry (RIPI)	64
4.1.4 Major Iranian Achievements in Oil & Gas Technologies	65
Part Two: New & Renewable Energies	70
4.2.1 Introduction	70
4.2.2 Renewable Energy Organization of Iran (SUNA)	70
<b>5. Advanced Materials (The case of Composites Technologies)</b>	
5.1 Introduction	75
5.2 Current Status of Composites Technologies in Iran	75
5.3 Iran Composites Institute (ICI)	76
5.4 Major Iranian Composites Achievements & Products	77
<b>6. Information and Communication Technology</b>	
6.1 Introduction	79
6.2 Current ICT Status in Iran	79
6.3 Ministry of Information and Communication Technology	82
6.4 Iranian ICT Infrastructures	82
6.5 Sub-Industries of ICT	83
6.6 Major Iranian ICT Products	85
<b>7. Aerospace</b>	
7.1 Introduction	93
7.2 Alborz Space Center	93
7.3 Some Iranian Achievements in Aerospace	94

# Contents

---

<b>8. Water and Wastewater Technologies</b>	
8.1 Introduction.....	99
8.2 Current Water Resources in Iran.....	99
8.3 Major Iranian Water Industry Achievements & Technologies.....	100
<b>9. Marine Industries</b>	
9.1 Introduction.....	103
9.2 Current Status of Marine Industries in Iran.....	103
9.3 Major Iranian Achievements in Different Fields of Marine Industries.....	104
<b>10. Some of the Road, Housing &amp; Urban Development Research Center Projects</b>	

# Tables

Table 1-1 University students in Iran (2011-2012) .....	4
Table 1-2 Higher education institutes and centers in Iran (2011-12) .....	5
Table 1-3 Iran research and technology budget.....	7
Table 1-4 Ratio of R&D budget to GDP, 2007-2013.....	8
Table 1-5 Comparison of the volume of R&D credits in major sections (million rials).....	8
Table 1-6 S&E articles in all fields, by country/economy- 1999-2009.....	11
Table 1-7 Published ISI articles in the world, comparison between 2011 & 2012.....	12
Table 2-1 Current biotechnology position of Iran in the world.....	13
Table 2-2 Some other Iranian biotechnology achievements.....	38
Table 3-1 Top 30 countries by published nano-articles in 2012.....	44
Table 3-2: Contribution of Iran's nano articles compared to total ISI articles in countries with more than 500 ISI articles in 2012.....	45
Table 3-3 Iran nanotechnology statistics.....	46
Table 3-4 Iran's nanotechnology instruments and products in various industrial sectors.....	48
Table 5-1 Composites technology status in Iran.....	76
Table 6-1 Some Iranian telecommunication statistics.....	80
Table 6-2 Internet Growth and Population Statistics.....	82
Table 6-3 Indexes for ICT Infrastructure for selected countries, by economic sector, 2010.....	83

# Figures

Figure 1-1 Iran population by age groups and gender.....	2
Figure 1-2 Iran's GDP growth, 2005-2013.....	2
Figure 1-3 Percentages of students by field of study (2011-12) .....	4
Figure 1-4 Growth in the number of parks during 2005-2012.....	6
Figure 1-5 Science and Technology incubators, 2005-2011.....	7
Figure 1-6 Top 40 countries by number of research papers published (2011) .....	9
Figure 1-7 Growth of ISI articles of the Islamic Republic of Iran, 1970-2012.....	10
Figure 2-1: Comparison of the state of patients needing insulin, before and after treatment.....	20
Figure 3-1 INIC organizational structure.....	40
Figure 3-2 Iran's international ranking for nanotechnology articles in the period 2000-2012.....	43
Figure 3-3: Distribution of areas of activities of nanotechnology companies in Iran.....	47
Figure 4-1 Largest proven reserve holders of oil, January 2013.....	61
Figure 4-2 Largest proven reserve holders of natural gas, January 2013.....	62
Figure 4-3 Proven crude oil reservoirs, % of world total, 2009.....	62
Figure 4-4 Proven natural gas reservoirs, % of world total, 2009.....	63
Figure 4-5 OPEC share of world crude oil reserves, 2012.....	63
Figure 5-1 Composites consumption and production per capita growth in Iran.....	76
Figure 6-1 Iranian major mobile operators market share.....	80
Figure 6-2 Middle East internet users, June 30, 2012.....	81
Figure 8-1 GPR Investigation growth in Iran (meter).....	101
Figure 8-2 Chlor-Ozone technology.....	101

# Iran at a Glance

The Islamic Republic of Iran is located in southwest Asia, in the Middle East region. The name "Iran" has been in use natively since the Sassanian era and came into use internationally in 1935, before which the country was known to the Western world as Persia. Iran has a rich and deep history and is home to one of the world's oldest civilizations.

Iran is the 18th largest country in the world with a land area of 1,648,195 km<sup>2</sup> and has land boundaries of 5,440 km. The country is bordered by 15 neighbouring countries, on the north by Armenia, Azerbaijan and Turkmenistan, on the east by Afghanistan and Pakistan,



on the south by the Persian Gulf and the Gulf of Oman, on the west by Iraq and on the northwest by Turkey. The Caspian Sea is located in the north of the country.

Tehran, the country's capital and largest city is the political, cultural, commercial, and industrial centre of the nation. The country is divided into 31 provinces, each governed by an appointed governor.

Iranian coastline totals 2,440 km. The country comes with varied topography, climate and eco-regions ranging from snow and rain forests to deserts. Its climate ranges from arid or semiarid, to subtropical along the Caspian coast and the northern forests. The highest point in Iran is Damavand Mountain (5,671 m) and the lowest point is in the Caspian Sea (28m).



Iran enjoys many natural resources, including petroleum, natural gas, coal, chromium, copper, iron ore, lead, manganese, zinc, and sulphur.

Natural hazards threatening the country include periodic droughts, floods, dust storms, sandstorms, and earthquakes.



In 2012, the population of Iran was estimated at 78,868,711 with a population growth rate of 1.25%. In the same year, the birth rate in Iran was 18.52 births/1,000 population. Figure 1-1 represents the estimated population of Iran in 2013 by age groups and gender. More than half of Iran's population is under 35 years old.

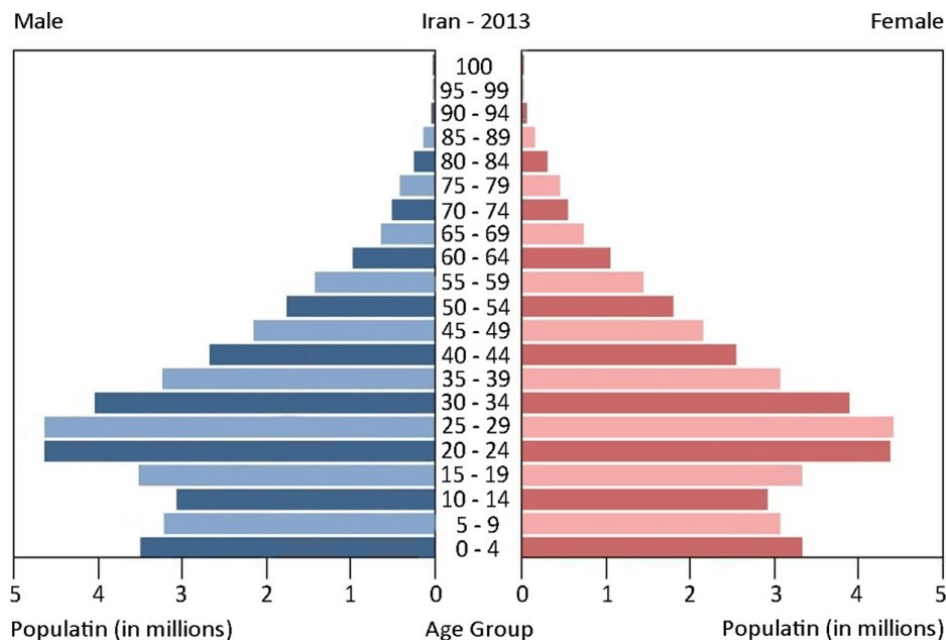

Figure 1-1 Iran population by age groups and gender

According to the statistics of the World Bank, the Gross Domestic Product (GDP) in Iran was 548.89 billion US dollars in 2012<sup>1</sup>, with an annual growth rate of 0.36. Figure 1-2 illustrates Iran's GDP growth between 2001 and 2013 according to the World Bank statistics.

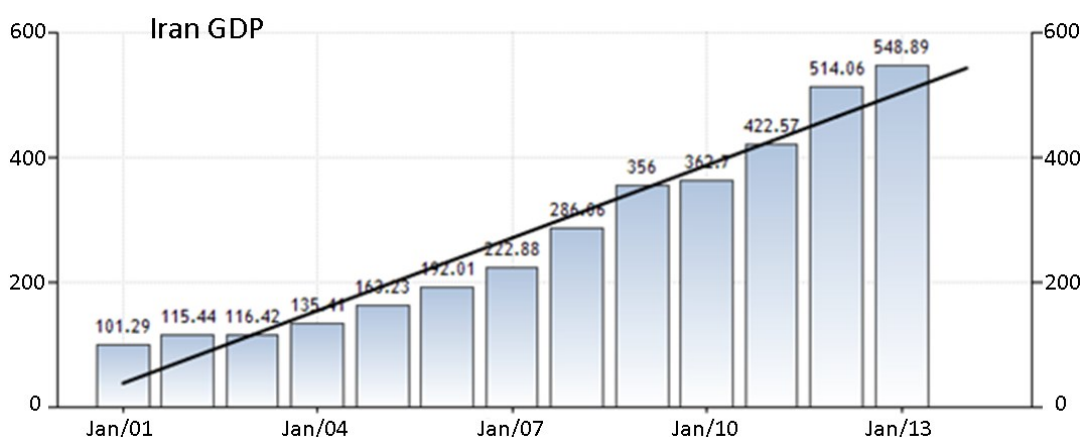

Figure 1-2 Iran's GDP growth, 2001-2013<sup>2</sup>

<sup>1</sup> <http://www.tradingeconomics.com/iran/gdp>

<sup>2</sup> World Bank

# 1. Iran's Science & Technology Status

## 1.1 Introduction

Over the past few decades, significant programs and initiatives were launched in Iran in the field of science and technology (S&T). The main program for promoting science and technology is Vision 2025, which aims to devote 2.5% of Iran's GDP to research. During the past 30 years, through education and training, dramatic progress has been achieved in almost all fields of technology including nanotechnology, biotechnology, aerospace, nuclear science, medical development, stem cell research, and cloning research.

## 1.2 Science and Technology Orientation

Upon understanding the fundamental role of science and technology in the development of the country, significant programs were launched in Iran aimed at gaining access to advanced and high technologies, thereby enhancing the country's capacity for development.

The main programs for promoting science and technology include Vision 2025, Iran Science and Technology Mega Map (2009), High Technology Industrial Zones, and the establishment of National Strategic Technology Initiatives (2005).

Vision 2025 was planned to promote the position of the Islamic Republic of Iran in national,



regional, and international levels in order to progress into a developed country within the next twenty years with a leading economic, scientific, and technical status in the region.

### 3.1 Iran's Science & Technology Statistics

Iran has made considerable advances in almost all aspects of research through education and training during the past 30 years, and has had the fastest science progress rate in the world.

**Students:** Iran's university population swelled from 100,000 in 1979 to 4,404,614 in 2012. Table 1-1 shows the distribution of Iranian student population in 2011-12 by gender<sup>1</sup>.

Table 1-1 University students in Iran (2011-2012)

Gender	Population
Male	2,213,205
Female	2,191,409
Total	4,404,614

The distribution of Iranian university students by field of study in 2011-12 is shown in figure 1-3. As the figure shows, in terms of field of study, the students of humanity courses were the highest (about 45%), followed by students of engineering courses (32.5%); while the students of medical sciences were the lowest (4.30%).

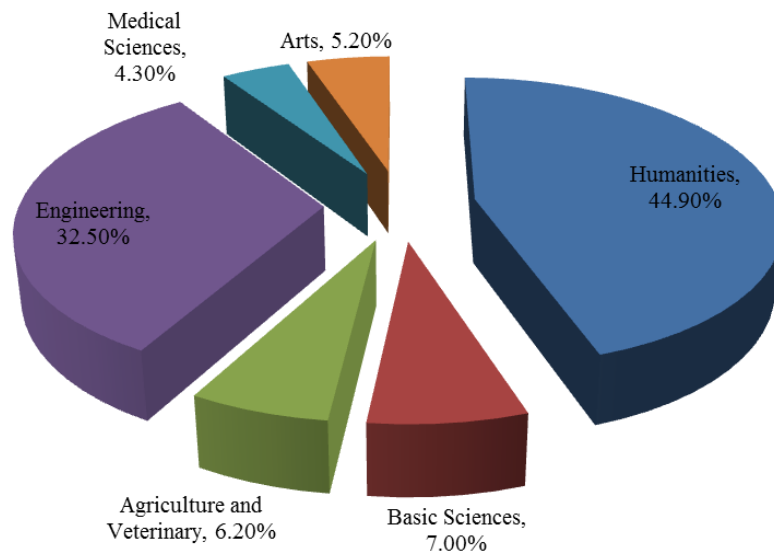

Figure 1-3 Percentages of students by field of study (2011-12)

<sup>1</sup> All educational statistics are from MSRT

**Higher education institutions:** Institutions engaged in higher education in Iran consist of government institutions (public universities, etc.), all affiliate to the Ministry of Science, Research and Technology (MSRT); and non-governmental institutions (Islamic Azad University, non-profit organizations). Table 1-2 represents the statistics of higher education institutes and centres in Iran.

Table 1-2 Higher education institutes and centers in Iran (2011-12)

<b>1- Governmental Higher Education Sector (Affiliated to MSRT)</b>	
Universities	105
Independent schools	16
Higher education centres	9
Institutes	135
Payam-e-Noor University local study centres and campuses	500
Universities of Applied Science and Technology	169
<b>2- Non-Governmental Education Centres/ Private higher education</b>	
Non-profit institutes	285
Islamic Azad University branches (inside the country and abroad)	406
<b>Total</b>	<b>1625</b>

**Parks:** At the moment, there are 33 science and technology parks in the country. 87.1% of science and technology parks are affiliated to the Ministry of Science, Research and Technology. Figure 1-4 shows the growth of parks in Iran in the period between 2005 and 2012, indicating a significant growth.

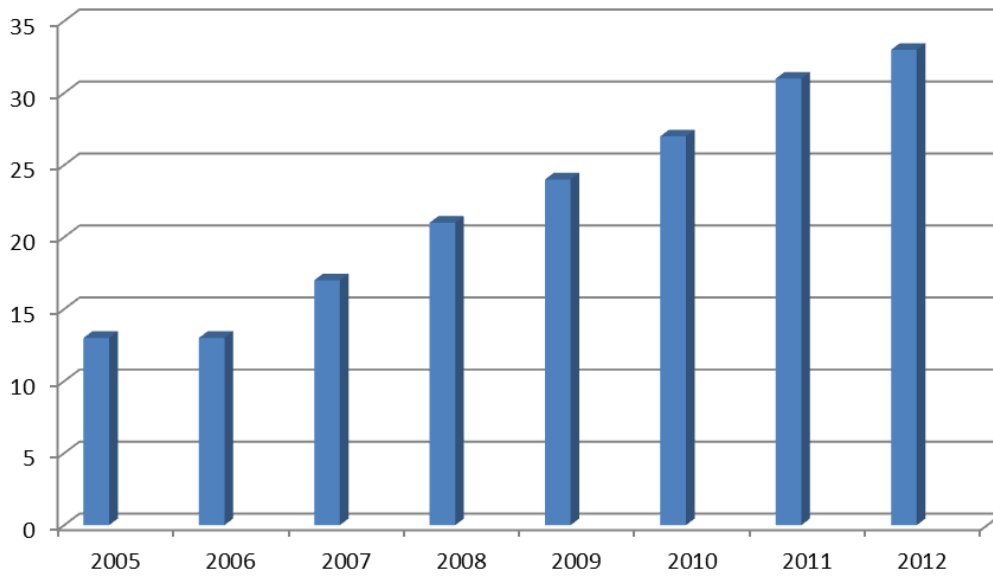

Figure 1-4 Growth in the number of parks during 2005-2012

In addition, the distribution of science and technology parks in Iran is illustrated in the map below.



**Science and technology incubators:** In 2011, there were 117 established science and technology incubators in Iran. Compared to 2005, science and technology incubators increased by more than 28% in 2011. Figure 1-5 shows the growth of science and technology incubators in Iran during 2005-2011.

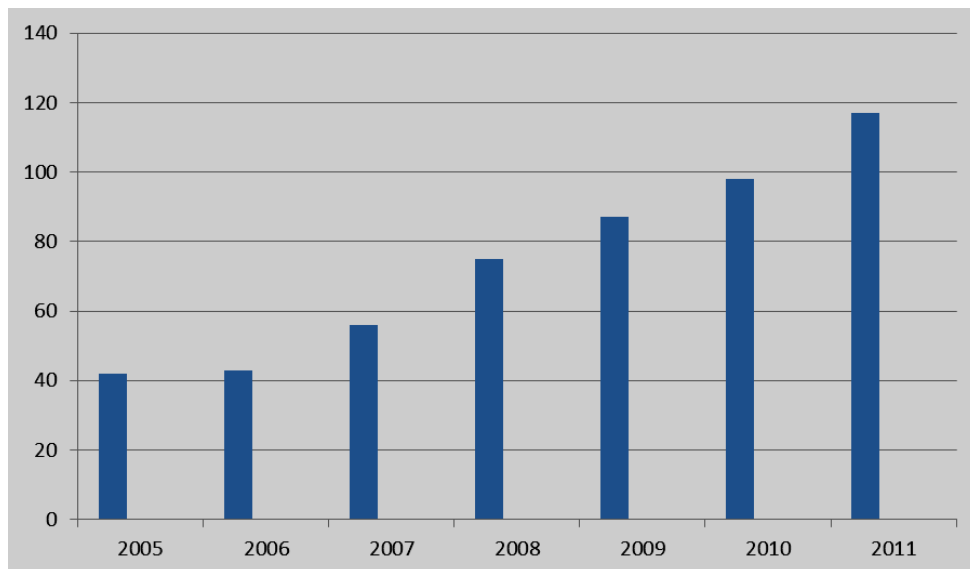

Figure 1-5 Science and Technology incubators, 2005-2011<sup>1</sup>

**Research and technology budget:** Iran’s research and technology budget allocation for 2013 is 47,974,713 million rials. Table 1-3 compares the budget allocation for research and technology in three consecutive years.

Table 1-3 Iran research and technology budget (million rials)<sup>2</sup>

	2011	2012	2013
R&D Funding in budget law	32,472,716	39,557,142	43,917,687
S&T development and innovation funding programs (excluding R&D)	3,055,413	3,626,565	4,057,026
Total	35,528,129	43,183,707	47,974,713

<sup>1</sup> MSRT publications

<sup>2</sup> Iran Budget Law, also 2 next table

Table 1-4 represents the ratio of Public R&D Budget to GDP in Iran in the period between 2007 and 2013.

Table 1-4 Ratio of R&D budget to GDP, 2007-2013

Year	Public R&D Budget (million rials)	Ratio of Public R&D Budget to GDP
2007	10,163,992	0.35
2008	14,284,068	0.42
2009	19,874,777	0.56
2010	18,833,435	0.44
2011	22,814,102	0.44
2012	30,401,531	0.49
2013	30,986,305	0.42

The distribution of R&D funds among major sections dealing with research and development is presented in table 1-5.

Table 1-5 Comparison of the volume of R&D credits in major sections (million rials)

Executive organization	Total funds of the budget bill (2013)	Share of to- tal (percent)
Presidency and Deputies	4,534,519	15
Ministry of Science, Research, and Technology, and the affiliated universities	10,771,816	36
Ministry of Health and Medical Education, and the affiliated universities	4,595,574	15
Ministry of Agriculture, and associate institutions	3,851,031	13
Ministry of Defence and associate institutions	837,503	3
Other organizations	5,543,793	18
<b>Total</b>	<b>30,134,236</b>	<b>100</b>

## 1.4 Iran's Science & Technology Publications

By 2011, Iran's science and technology article output made it the 20<sup>th</sup> largest science & engineering article producer in the world. As illustrated in figure 1-6, with a growth rate of 20% in the number of articles, Iran had the fastest growth rate among all nations in 2011, followed by China, South Korea, Spain, United Kingdom and United States (figure 1-6).<sup>1</sup>

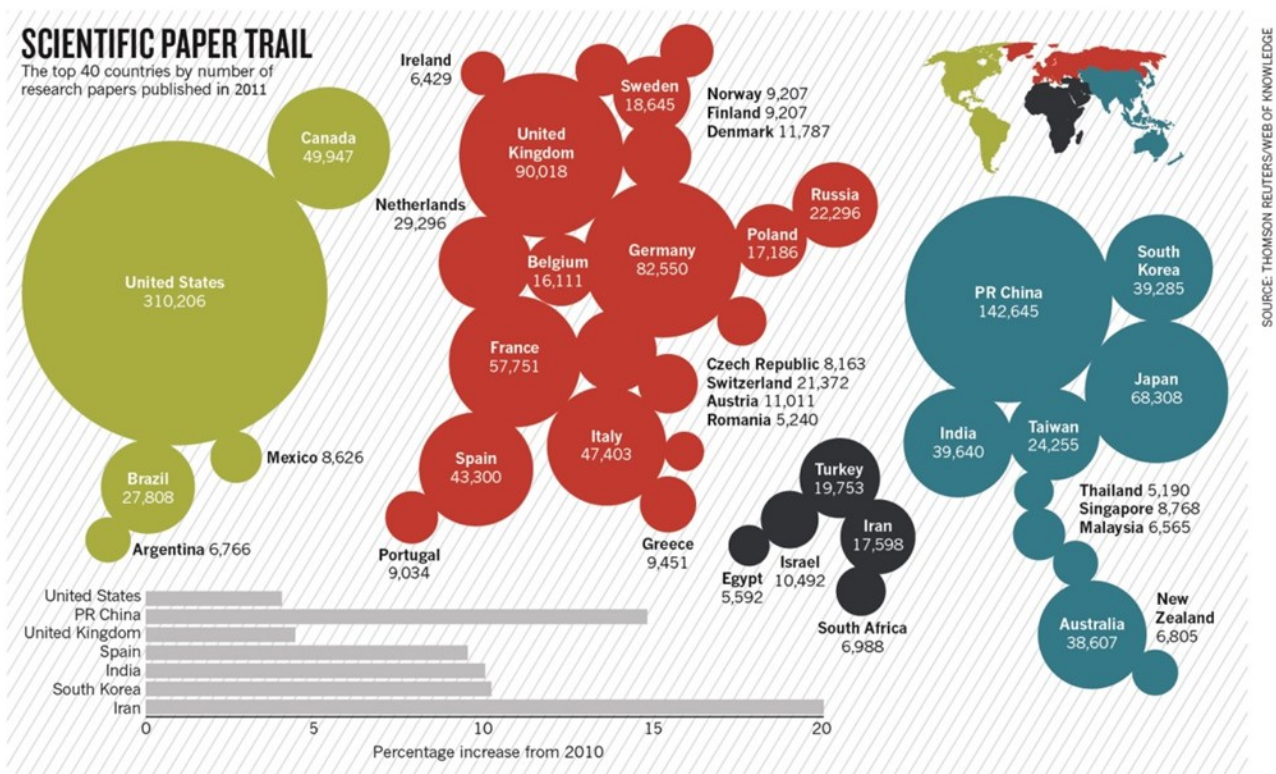

Figure 1-6 Top 40 countries by number of research papers published (2011)

<sup>1</sup> NATURE VOL 480 22/29 DECEMBER 2011



In 2012, the number of Iranian Science and Engineering (S&E) articles in all fields reached 20065, placing Iran as the 18<sup>th</sup> article producing country in the world (figure 1-6 & table 1-6).

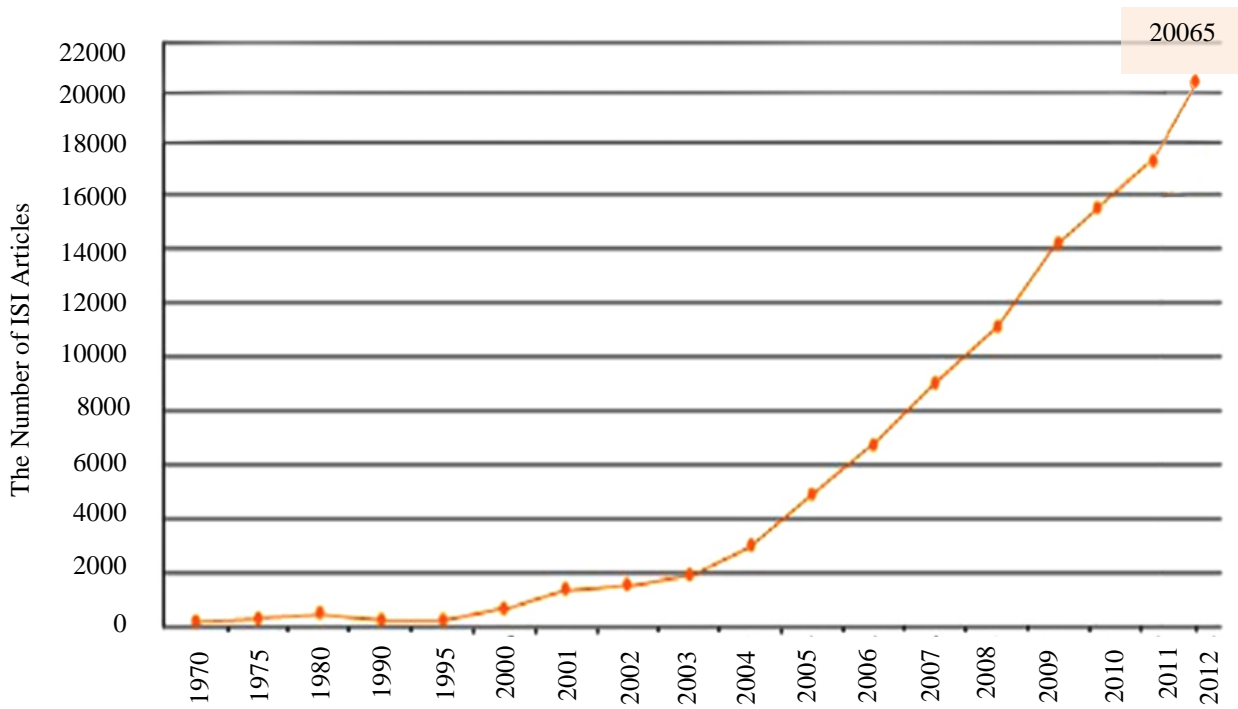

Figure 1-7 Growth of ISI articles of the Islamic Republic of Iran, 1970-2012

Table 1-6 Published ISI articles in the world, comparison between 2011 & 2012 <sup>1</sup>

Rank	Country	No. of Research Papers Published in 2011	No. of Research Papers Published in 2012	Rank	Country	No. of Research Papers Published in 2011	No. of Research Papers Published in 2012
1	United States	310206	311975	21	Poland	17186	17602
2	People's Republic of China	142645	159121	22	Belgium	16111	16442
3	United Kingdom	90018	86544	23	Denmark	11787	12376
4	Germany	82550	83216	24	Austria	11011	11132
5	Japan	68308	66820	25	Israel	10492	10844
6	France	57751	57320	26	Portugal	9034	10068
7	Canada	49947	51107	27	Norway	9207	9456
8	Italy	47403	48353	28	Finland	9207	9368
9	Spain	43300	44935	29	Singapore	8768	9347
10	South Korea	39285	41770	30	Greece	9451	9281
11	India	39640	40912	31	Mexico	8626	9034
12	Australia	38607	40901	32	Czech Republic	8163	8400
13	Netherlands	29296	30616	33	South Africa	6988	7625
14	Brazil	27808	29924	34	New Zealand	6805	7314
15	Taiwan	24255	23592	35	Malaysia	6565	7037
16	Russia	22296	22340	36	Argentina	6766	6866
17	Switzerland	21372	21796	37	Ireland	6429	6238
18	<b>Iran</b>	<b>17598</b>	<b>20065</b>	38	Saudi Arabia	N/A	6203
19	Turkey	19753	19396	39	Egypt	5592	5911
20	Sweden	18645	19421	40	Romania	5240	N/A

The subsequent updated National Science Foundation report published in 2012 by the US government under the name "Science and Engineering Indicators: 2012", has again put Iran first globally in terms of growth in science and engineering article output in the first decade of this millennium with an annual growth rate of 25.2%. <sup>2</sup>

<sup>1</sup> This table is prepared based on two papers, including NATURE VOL 480 22/29 DECEMBER 2011, and NATURE VOL 492 20/27 DECEMBER 2012

<sup>2</sup> <http://www.nsf.gov/statistics/seind12/pdf/seind12.pdf>

Iran's ranks for the year 2012 based on the number of published documents in different fields of technology are also illustrated in table 1-7.

Table 1-7 Iran's ranks in different fields according to the number of published documents (2012)

<b>Technology field</b>	<b>Rank in the World</b>
Biotechnology	14
Agriculture and Biological Sciences	12
Nanotechnology	8
Materials Science	11
Energy Engineering and Power Technology	6
Fuel Technology	4
Renewable Energies, Sustainability and Environment	16
Ceramics and Composites	12
Electronics, Optical, and Magnetic Materials	12
Aerospace Engineering	19

# 2. Biotechnology

## 2.1 Introduction

Iran has witnessed remarkable advances in the field of biotechnology in the last two decades, highlighted by breakthroughs in genetic engineering and related techniques. Hopes are rising that these advances may solve many of the problems facing human communities. Blood substitutes and antibiotics are among the increasing number of target products derived from plant-based biotechnology.

Providing better tools to fight pollution and better protection to the environment can strengthen the role of modern biotechnology in different aspects of development of third world countries such as diversifying production, increasing income sources, creating more job opportunities etc. Iran initiated research activities in biological sciences seventy years ago in Razi and Pasteur institutes, which were originally established to produce human and animal vaccines.

## 2.2 Current Biotechnology Status in Iran

Iran entered the modern biotechnology arena in the early 1990s, and within a short period of time demonstrated enhanced capabilities. At present, there are 160 public research and academic institutes as well as 218 private centres and companies involved in the field of biotechnology research and production in Iran.

In terms of published articles in comparison to other countries of the world, Iran ranks first in the Middle East and is one of top five countries in Asia. (Table 2-1)

Table 2-1 Current biotechnology position of Iran in the world

Published articles in comparison to other countries of the world <sup>1</sup>	Rank: 14 <sup>th</sup>
General ranking in terms of production in Asia	Among top 5 Countries
Production rate in the Middle East	Rank: 1 <sup>st</sup>
Vaccines production rate in the Middle East	Rank: 1 <sup>st</sup>
Currently producing 28 of the most expensive Biopharmaceuticals	

<sup>1</sup> <http://www.scimagojr.com>

### 2.3 Iranian Biotechnology Research and Development Priorities

As part of the national biotechnology program, the biotechnology commission has set up priorities for research and development in this area. These priorities were defined based on UNESCO criterion/index that identifies agricultural and medical biotechnology as the research and development priorities of this field.

Iranian Biotechnology activities in the field of health mainly include biopharmaceuticals, diagnosis, cell therapy, and regenerative medicine. In agriculture, the country is pursuing activities in the fields of biofertilizer, biopesticide, and tissue culture and in the field of environment; Iran's activities are mainly focused on waste treatment.

### 2.4 Iranian Biotechnology Centers

Major biotechnology centers in Iran include:

- Biotechnology Council
- Center for Innovation & Technology Cooperation (CITC)
- National Committee for Policy Making in Medical Biotechnology
- Agricultural Biotechnology Research Institute of Iran (ABRII)
- Biotechnology Department of Pasteur Institute of Iran
- Iranian Research Organization for Science & Technology (IROST)
- National Research Center for Genetic Engineering and Biotechnology (NRCGEB)
- Razi Vaccine & Serum Research Institute
- Royan Institute
- Avicenna Research Institute

Three of the above-mentioned organizations make decisions in the field of biotechnology at state level. These organizations include:

- **Biotechnology Council:** Members of this council include deputies for research from the Ministry of Health and Medical Education; Ministry of Agriculture; Ministry of Science, Research and Technology; directors of biotechnology research centres; and five expert scientists in biotechnology. Coordination of biotechnological research and priority settings is the primary responsibility of this council.
- **Center for Innovation & Technology Cooperation (CITC):** This center facilitates the transfer of advanced technologies from abroad. The department of Life Sciences in the CITC is responsible for technology transfer in the fields of biotechnology and pharmaceuticals.

- **National Committee for Policy making in Medical Biotechnology:** This committee is a branch of the Ministry of Health and Medical Education. It is responsible for enhancing and supporting research activities in the field of medical biotechnology. Directors of biotechnology centers, research deputies of the ministries, and the five biotechnology experts that were previously mentioned are also members of this committee.

## 2.5 Medical Biotechnology

In this section, after presenting a brief introduction to one of the most important organizations in the field of medical biotechnology, Pasteur Institute of Iran, some of the main achievements in this field are introduced.

### 2.5.1 Pasteur Institute of Iran

Pasteur Institute is one of the most important biotechnology organizations in Iran which conducts applied researches on basic medical health sciences and diagnosis of various diseases.

Located in the heart of the Iranian capital, Tehran, Pasteur Institute of Iran was established over 80 years ago to combat diseases and promote health in the country. Pasteur Institute of Iran is governed by the board of trustees and is affiliated to the Iranian Ministry of Health. The institute also maintains a close relationship and active cooperation with international organizations such as the World Health Organisation (WHO) and the Institute Pasteur International Network. The aims and objectives of Pasteur Institute of Iran include:

**“expansion of applied research on biological products as well as research in basic sciences in order to introduce and optimize new techniques and methods in applied research, with a particular emphasis on infections”.**

#### Pasteur Institute Policies

- Conducting basic and applied research on diagnosis of various diseases
- Conducting basic and applied research to meet the needs of the country
- Conducting research on basic medical health sciences
- Arranging independent training courses in various specialized fields

## 2.5.2 Major Achievements in Medical Biotechnology

### ANGIPARS™

ANGIPARS™ is a novel drug for management of diabetic foot ulcer and prevents amputation. It has significant effects on diabetic wounds, showing its effects prior to the second week of use.



#### Features

- Completely safe in terms of therapeutic doses
- Significantly effective in the treatment of diabetic foot ulcer
- Remarkable therapeutic effects as early as the second week of the therapy
- Durable therapeutic effects (even after finishing the treatment course)
- Cost effective therapy
- Preventing amputation in patients with diabetic foot ulcer
- Long durable drug
- A herbal drug containing Mellilotus Officinalis dried extract

*Before application*



*After application*



*Before application*



*After application*



## Pharmacological effects

- Improvement in blood circulation and Lymph flow
- Anti thrombophlebitic activity
- Anti-inflammatory and anti-edema effect
- Anti-oxidant activity via scavenging free radicals and NO release



## IMOD™

IMOD™ is a medicine for treatment of HIV/AIDS. In 2001, a novel idea for the treatment of HIV-infected and AIDS patients was proposed in Russia. An expert group of one Russian and four Iranian scientists was formed to plan and conduct the research process in Iran. After intensive toxicology studies, the drug candidates went through several clinical trials which finally resulted in introduction of a novel herbal drug, called IMOD™.

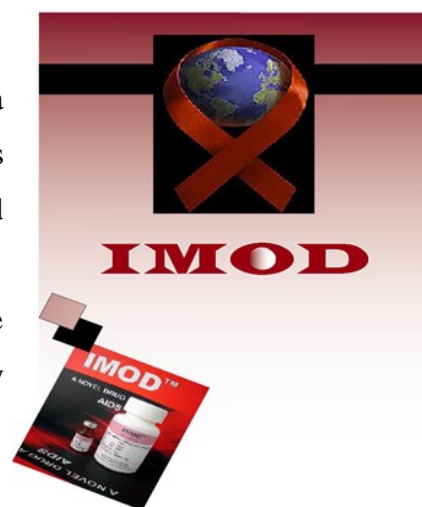

## Features

- Stimulates the immune system by increasing white blood cell count and consequently inducing resistance against diseases
- Prevents HIV patients from entering the AIDS stage
- Helps patients with AIDS to recover and experience a normal life
- Relatively low cost compared to similar commercial drugs
- No side effects
- Highly effective
- Durable effects (even after finishing the course of treatment)



## **CinnoVex™**

CinnoVex™ is the trade name for recombinant Interferon beta 1-a, which is used for the treatment of relapsing Multiple Sclerosis (MS). The value of 1 gr. of CinnoVex™ costs 2.5 million US dollars. It is also worth noting that Iran is the third country in the world that is able to produce CinnoVex™.



### **Features**

- Slows down the development of physical disability
- Delays the progression of disability milestones – significantly reduces the risk of progression to impaired ambulation
- Significantly delays the onset of persistent deterioration in manual dexterity and timed ambulation
- Reduces the rate of progression of brain disorder
- Reduces the number of enhancing lesions

## **GAMA- IMMUNEX™**

Interferon gamma-1b is made from human proteins and helps the body to fight viral infections.

### **Features**

GAMA-IMMUNEX™ is a particular type of interferon used to reduce the frequency and severity of serious infections caused by a genetic disorder called Chronic Granulomatous Disease (CGD). It is often used along with antibiotics to help prevent these serious infections. This medicine is also used to slow down the progression of another genetic bone disease called malignant osteoporosis which is a type of hereditary osteoclast disorder.

### **Advantages of g-Immunex™ in comparison with similar foreign Products**

- After the United States and Germany, Iran is the third country in the world which produces Interferon gamma-1b.
- The price and quality of g-Immunex™ produced by EXIR Pharmaceutical Company is comparable to similar foreign products.



### **Cell Therapy**

In cell therapy, hematopoietic cells are used for the treatment of certain refractory diseases. Given the frequency of such diseases in the country, domestic and foreign experts utilize cell therapy to study refractory diseases such as Multiple Trauma, Cancer, Duchenne Syndrome, Diabetes, and MS.

### **Advantages of Hematopoietic Cells**

- Extracting cells from human embryos and applying them without in vitro cultivation or adding any biological or chemical materials;
- Avoiding the need to use any chemical or toxic drugs to suppress the immune system thereby decreasing the chance of poisoning;
- High chance of transplantation - no case of cell disposal has been observed in over 20 years;
- Little or no acute complications have been reported;
- Little or no stimulation in the immune system of the recipient has been observed, in comparison with similar methods;
- Applicable for all age ranges;
- Affordable cost;
- No need to find a source supply (donor) that meets the patient's needs, since it can be supplied from a cell bank and has higher reconstruction power in comparison with similar cells from other resources (bone marrow or blood cells);
- More stem cells are present per volume unit in the embryo in comparison with bone marrow or blood cells.

### Unique Advantages of Hematopoietic Cells

- These cells are extracted from the fetal liver, which are similar to Hematopoietic cells of bone marrow in adult human beings and their proliferation potential is much higher than similar cells originating from adult bone marrow.
- In these cells, the antibody genes that stimulate the immune system of the recipient and reject the transplant are non-existent.
- High sensitivity to humoral factors leads to proliferation and migration of these cells to the injured tissue and helps to relieve injury.
- Biologically active factors that are extracted from fetal liver are effective tools in restoring the function of cells and damaged tissues of the recipients.

Figure 2-1 illustrates the state of patients in need for insulin, before and after treatment with Hematopoietic Cells.

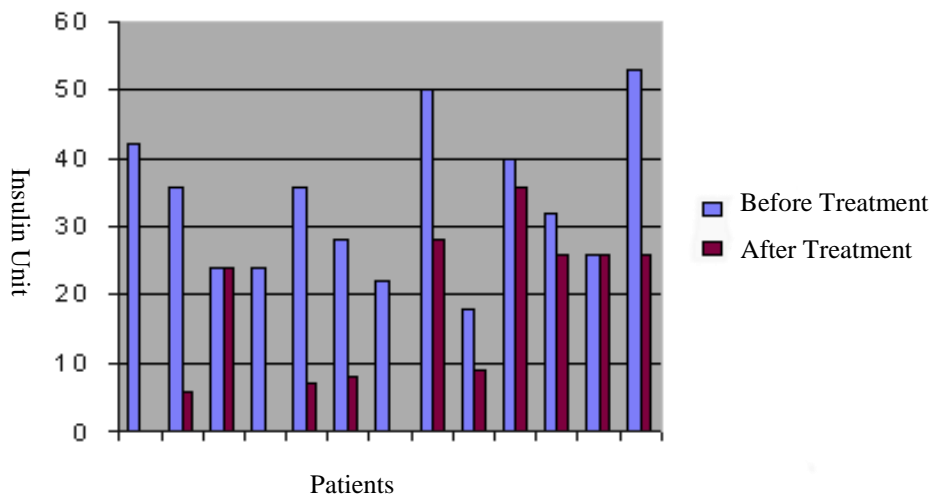

Figure 2-1: Comparison of the state of patients needing insulin, before and after treatment

### Hepatitis B Vaccine

Produced for active immunization against the HBV infection and prevention of consequences such as acute and chronic hepatitis, cirrhosis, liver failure, and primary liver carcinoma.





bone fracture.

- Treatment of men and women osteoporosis associated with sustained systemic glucocorticoid therapy who are at high risk of bone fracture.
- High fracture risk is defined as a history of osteoporotic fracture, multiple risk factors for fracture, or failure or intolerance to other available osteoporosis therapies.

### **Cinnal-f®- Follitropin Alfa**

- A human follicle stimulating hormone (FSH) preparation of recombinant DNA origin.
- Indicated for induction of ovulation and pregnancy in anovulatory infertile patients without primary ovarian failure.
- Indicated for induction of spermatogenesis in men with primary and secondary hypogonadotropic hypogonadism.
- Indicated for development of multiple follicles in the ovulatory patient participating in an Assisted Reproductive Technology (ART) program.
- Is a single-dose vial which delivers 75 IU for SC injection.

Cinnal-f® (recombinant follitropin alfa for injection) is prescribed to supplement or replace naturally occurring FSH, an essential hormone to treat infertility in both women and men.

Cinnal-f® is a human FSH preparation of recombinant DNA origin. Recombinant FSH preparation occurs in genetically modified Chinese Hamster Ovary (CHO) cells cultured in bioreactors.

### **Usage**

Cinnal-f® is indicated for:

- Induction of ovulation and pregnancy in anovulatory infertile patients whose infertility is functional and not due to primary ovarian failure.
- Development of multiple follicles in the ovulatory patient participating in an Assisted Reproductive Technology (ART) program.
- Induction of spermatogenesis in men with primary and secondary hypogonadotropic hypogonadism.

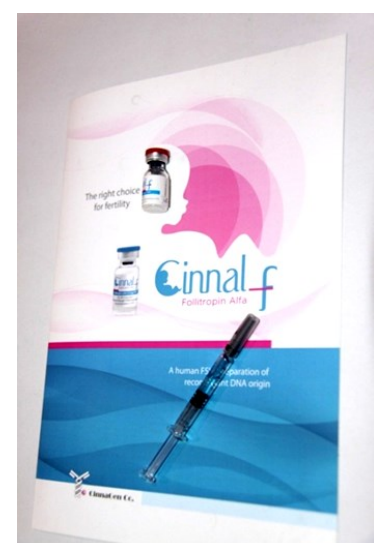

## FACTOR VII

Recombinant activated coagulation factor VII is structurally similar to human plasma extracted factor VII, when coagulation factors do not act correctly, this Vitamin K-dependent glycoprotein forms clots at the site of bleeding.

rFVIIa is used for treatment of bleeding episodes and also for prevention of bleeding when undergoing surgery or other invasive procedures in patients with following diseases:

- Congenital hemophilia A or B with inhibitors;
- Congenital hemophilia A or B with a history of hypersensitivity to coagulation factor VIII or IX;
- Acquired hemophilia;
- Congenital factor VII deficiency;
- Glanzmann's thrombasthenia disease (a bleeding syndrome).

### Medical uses

Recombinant factor VIIa with trade names of AryoSeven and Novoseven is used for patients with hemophilia (with Factor VIII or IX deficiency) who have developed inhibitors against replacement coagulation factor.

It has also been used in the setting of uncontrollable hemorrhage but its role in this setting is controversial with insufficient evidence to support its use outside of clinical trials. Risks of its use include an increase in arterial thrombosis.



### 2.6 Medical Equipment

This section consists of two parts. The first part gives a brief introduction to the most important organization in Iran dealing with medical equipment, and in the second part major Iranian achievements in the field of medical equipment are introduced.

#### 2.6.1 Institute for Advanced Medical Technologies (IAMT)

The Institute for Advanced Medical Technologies (IAMT) is one of Iran's pioneering organizations in the field of manufacturing medical equipment. The research projects accomplished in this center have been awarded many national and international prizes.

Some of the outstanding achievements in medical equipment development include: Parseh Surgical Navigation System, Robolens, Auto Acoustic Emission for Infants' Hearing Screening and many more.

Institute for Advanced Medical Technologies (IAMT) was established in 2010 as a result of successful endeavours made by researchers in the Research Center for Science and Technology in Medicine (RCSTIM). RCSTIM is the first research center in Iran for the application of science and engineering in medicine which was established in the public hospital complex of Imam Khomeini in 1994, and it is affiliated to Tehran University of Medical Science (TUMS).

IAMT aims at expanding knowledge frontiers, promoting education and research, and training capable human resources for advanced medical technologies at the global level in order to develop and promote the health level in the country. It also aims to identify and assist in meeting the demands of different health and treatment service sectors in the country for development and application of technologies, and finally to create appropriate interactions with experts and innovators from national and international scientific and research centers.

At the moment, the Institute consists of 3 research centers, including:

- Biomedical and Robotics Technology,
- Molecular Imaging, and
- Tissue Engineering and Stem Cell research.

There are more than 16 faculty members in IAMT who are working on research projects in cooperation with more than 70 researchers (BSc, MSc, and PhD students), and 30 administrative and supporting staff.

**“Some of the achievements of this institute include publication of more than 250 articles in national and international journals, presenting more than 220 articles in national and international conferences, and publication of 9 books. Moreover, the research projects accomplished in this center have been awarded more than 16 national and international prizes and over 10 national and 2 international patents have been registered by this Institute”.**

Some of the high-tech products of this institute are the Nano-scope, Parseh surgical navigation system, imaging system for small animals, surgical retractor, auto-acoustic emission, surgical assistant robot, and Electroris.

## 2.6.2 Major Achievements in Medical Equipment

### Parseh Surgical Navigation System

Parseh surgical navigation system improves clinical outcomes by enabling surgeons to perform more precise procedures.



#### Features & Advantages

- Detailed 3D indication of the path for movement of surgical instruments
- Makes use of advanced techniques for the analysis and recovery of data provided by common medical imaging methods such as MRI and CT scan
- Considerable increase in the accuracy and quality of surgery
- Displays a virtual sight of the patients anatomy on the computer screen from surgery positions that are not in the surgeons direct field of view
- The most important application fields include brain and neurosurgery, otolaryngology surgery, orthopaedics surgery, spine surgery, and radiotherapy among others

### Robolens

Robolens is a new design of robotic assistance for laparoscopic surgeries that helps the surgeon by holding and moving the laparoscopic lens (camera) under their supervision during surgical operations. It can be controlled by voice commands of the surgeon or by a smart foot switch system under the surgeon's foot.





### **Advantages of Robolens over Human Assistant Surgeon**

- Reduces the time of surgery.
- Eliminates movement errors, picture vibration, and lens smudge
- Needs fewer technicians and thus increases space for the surgeon
- Holds and moves the laparoscopic lens according to the surgeon's order

Advantages of this robot in comparison with similar robots include view fixation without any rotation from the right angle, making use of minimum active degrees of freedom, simple function, smooth movement of the lens with constant speed in any situation, high movement safety and automatic stop in contact with inner viscera, and capability of preparing for surgery in less than 30 seconds.

### **Auto Acoustic Emission for Infants' Hearing Screening**

Auto Acoustic Emission is an advanced medical machine for Infant's Hearing Screening.



### **Features and Advantages**

- No need for patient cooperation
- Applicable for infants
- Low price compared to similar foreign-made products
- Peripheral product within the natural hearing process
- Recordable through the exterior ear canal
- Possibility of recording the nanometric oscillation by installing a hypersensitive probe inside the exterior canal of the ear
- Can be used for other clinical applications such as differentiation of cochlea malfunctioning, examining the recent impacts of poisonous drugs on hearing or other body parts, and examining the effects of electromagnetic waves on humans

## SAADAT Patient Care Monitors

SAADAT Patient Care Monitors enable healthcare professionals to evaluate their patients quickly through vital signs such as body temperature, pulse rate, respiration rate, blood pressure, and blood oxygen saturation. These monitors help healthcare professionals to attend to other tasks more efficiently and focus on improving patients' health. SAADAT products are compact and portable, so they can be used in ambulances, emergency rooms, ICU, CCU, NICU, as well as operating and recovery rooms. SAADAT products have been exported to more than 30 countries including Italy, Germany, Poland, Russia, and Turkey.



## Fermenter

A fermenter is a machine for processing organic material involving microorganisms or their derived substances. These processes can be either aerobic or anaerobic. Fermenters are commonly cylindrical, with various sizes, and are often made of stainless steel. According to its function, a fermenter may be classified as batch, fed batch or continuous (e.g. a continuous stirred-tank reactor model).

Manufacturing a fermenter is a complex engineering task. The main purpose in designing and manufacturing a fermenter is to provide optimum conditions in which microorganisms or cells can perform their desired function with a 100 percent rate of success. The fermenter's environmental conditions such as gas flow rate, temperature, pH, dissolved oxygen levels and agitation speed/circulation rate need to be closely monitored and controlled. Most industrial bioreactor manufacturers use vessels, sensors, and a control system networked together. Two types of fermenters are presented below;

- **Laboratory Fermentation System**

These fermenters are equipped with built-in accurate controls for pH, DO, temperature, agitation, and foam level. The autoclavable vessel and easy-to-use control system make these fermenters suitable for laboratories, research, and small scale production.



### Features and advantages

- Low-cost system, adaptable to individual requirements for measurement and/or control of temperature, pH, DO, foam, and nutrients
- A fully computerized control system without the need for a separate PC
- Easy uncoupling to facilitate cleaning and autoclaving
- Optional low-shear impellers to expand range of application
- Exhaust gas condenser to minimize evaporation
- Customized options

- **Pilot scale fermenters**

These fermenters are appropriate for pilot and small scale production. They are mobile with an average size that can be easily used in different places and a vessel volume which ranges from 20 to 1000 Litres. Sterilization system in these fermenters is SIP.

### Features and advantages

- Complete sanitary stainless steel design
- Automatic SIP sequence
- Application driven integrated gassing system
- User-friendly touch screen interface for easy operation
- Optional Redox and Turbidity measurement
- Optional manual or automatic pressure control



### **Milibioreactor**

Milibioreactor determines the oxygen transfer rate (OTR), carbon dioxide transfer rate (CTR), and respiratory quotient (RQ) of microbial, plant, and cell cultures online. The respiration rates (OTR, CTR) are the most suitable measurable variables to quantify the physiological state of fermented cultures.

The advantages of this bioreactor include 75% saving in time, 80% saving in consumption of raw materials, and ease of operation. The bioreactor can handle bio-reaction of cells, microorganisms such as bacteria, yeast, fungi, animal, as well as plant cells in research applications such as pharmaceutical laboratory science, medicine, food, environmental, and oil industry. It is also used to determine the optimum operating conditions in biotechnology products such as human proteins, enzymes, medicine and scale up procedure for biotechnology processes.

Direct on-line monitoring of a cell's metabolism including pH, substrate concentration, nutrients rate (vitamins, phosphorus, and nitrogen), biomass cells, enzymes and protein production and its effects on the growth of Microorganisms and cells are among the features of this apparatus. Yet another application of Milibioreactors is in studying the effects of applying nanoparticles in toxicology of cells and stem cell growth.

Milibioreactor is an appropriate tool for meeting the PAT initiative of the FDA regarding shaken bioreactors.

### **Advantages**

- Multiple parallel fermentations (4 or 8, by order)
- Very easy handling (set up as fast and easy as a normal shake flask)
- Availability of a single system for animal/human, microbial, and plant cells
- Automated system
- Non-stop applicability (short set-up time)
- Substitution of expensive fermentations in stirred bioreactors
- Optimization of screening conditions in shaken bioreactors
- More information about cultures in shaken bioreactors
- Rapid optimization of media
- Ensuring a secure scale-up by providing important values such as OTR, CTR, RQ,  $\mu$ MAX, etc.
- Reduction of the optimization time and time to market
- Substitution of expensive and time consuming offline analytics
- Intuitively operated software

### **Fields of application**

- Screening for an optimal production strain
- Medium optimization
- Quality control of complex compounds
- Optimization of complex compounds
- Optimization of the inoculums for fermenters
- Testing the effects of different compounds on the culture
- Improvement of scale-up
- Bio process development

## Economic Advantages

Field of application	Normal procedure	Procedure with Milli Zist Payesh	Savings
Raw material	2250ml	290ml	87%
Optimization time	80Hr	53Hr	34%
Labour time	16.5Hr	4.1Hr	75%

## Microchips to help the spinally impaired walk

This system is a portable microcomputer with a microchip that recreates the function of the motor cortex of the human brain in initiation and control of movements for the disabled, and contracts muscles by sending electrical signals to motor neurons, creating and controlling motor movements in paralyzed limbs.



### Features

The Parawalk system controls the range of paralyzed muscle contraction throughout movement using mathematical patterns of skeletomuscular systems and control strategies.

Patients with impairments in the waist area ranging in severity from T4 to T12 can gain relief from the system.



## 2.7 Agricultural Biotechnology

In this section, two main organizations of agricultural biotechnology are briefly introduced followed by presentation of some major Iranian agricultural biotechnology products.

Besides many agricultural biotechnology companies in the private sector, Agricultural Biotechnology Research Institute of Iran (ABRII) and National Institute of Genetic Engineering and Biotechnology (NIGEB) are the state research centers of excellence working on advanced plant molecular biology and biotechnology in close contact to pertinent departments in universities. Some of the commercialized Iranian agricultural biotechnology products include: Seed Potato Roytuber™, Phosphate Biofertilizer BARVAR-2™, AzotoBarvar-1™ Biofertilizer, Nitro Kara™ Biofertilizer Tissue culture plant, Veterinary Products such as Vaccines, Antisera, Diagnostic Kits and etc. Apart from these advances, Iran has excellence in many other agricultural biotechnology fields such as introduction of transgenic plants including stem-borer resistant rice, pest-resistant cotton, and rhizomania-resistant sugar beets as well as micro-propagation protocols for several plants and diagnostic methods or kits for many plant diseases. Attempts for bio farming of pharmaceuticals in both plants and animals are persuaded as well.

### 2.7.1 Agricultural Biotechnology Research Institute of Iran (ABRII)

The Agricultural Biotechnology Research Institute of Iran (ABRII) is one of the national agricultural research institutes under the supervision of the Agricultural Research and Education Organization (AREO). AREO is a communal organization of the Ministry of Agriculture. ABRII was established in 1983 as the Plant Biotechnology Department of the Seed and Plant Improvement Institute (SPII) which was later upgraded to the level of an independent institute in 1999. ABRII's research activities are mainly focused on the field of advanced plant molecular biology and biotechnology. As a national research institute, ABRII strives to promote applied research in plant science and technology, and organizes workshops for advanced training of experts who are involved in R&D in the field of agricultural biotechnology.

ABRII has six research departments, namely: genomics; tissue culture and gene transformation; microorganisms and biosafety; physiology and proteomics; technical services and research support; and genetics, cellular and molecular biology.

In addition, ABRII enjoys several modern and well-equipped research facilities comprised of trial fields and lysimeters, several green houses and controlled rooms, 10 walk-in phytotrons, cold rooms, and tissue culture facilities. Scientific staff of the institute consists of more than 100 researchers.

### 2.7.2 National Institute of Genetic Engineering and Biotechnology (NIGEB)

The National Institute for Genetic Engineering and Biotechnology (NIGEB) was established in 1989 under the supervision of the Ministry of Science, Research and Technology. The activities of this institute are mainly focused on five areas including medical biotechnology, plant biotechnology, animal and marine biotechnology, industrial and environmental biotechnology, and basic sciences. There are five departments in this institute concerning each of its activity areas.

NIGEB's Department of Plant Biotechnology consists of over 20 researchers mainly focused on plant improvement towards tolerance to abiotic and biotic stresses. Exploring plant responses to environmental conditions allows for the genetic engineering of plants with desired characteristics. The general theme of the abiotic stress research group is isolating genes and promoters involved in plant response to low phosphate and high salt stresses. In the biotic research group, great accomplishments have been reached with production of transgenic sugar beet plants that are resistant to rhizomoniasis and rhizoctonia disease by means of plantibody or gene silencing against BNYVV coat protein and also herbicide resistance in crops.

### 2.7.3 Major Agricultural Biotechnology Products

#### Seed Potato Roytuber™

Royan Tolou Company has introduced a novel method for producing large volumes of a healthy and virus-free seed potato called Roytuber. This was achieved through advanced and economical gardening processes.



#### Features and Advantages

- Introduces a new system of minituber production through scientifically advanced horticultural processes for production of large volumes of Roytuber seed potato propagules from virus and pathogen free nuclear materials
- Enables farmers to economically produce high yielding virus-free seed potato
- Reduces the reproduction period of the seeds from 10 years to 4 years
- Allows 80% saving in water consumption, nutrient solution, and energy
- Increases the quality and quantity of seed potato production
- Improves the quality of processed potato products (such as potato chips, fried potatoes, starch, and so on)
- Expansion of this technology can be used for all potato types



## Plant Tissue Culture

Tissue culture is the *in vitro* aseptic culture of cells, tissues, organs or whole plants under controlled nutritional and environmental conditions often to produce clones of plants. The resulting clones are true-to type of the selected genotype. Plant tissue culture technology is widely used for large scale plant multiplication and there are many private companies in our country that produce tissue culture plant rootstocks such as apple, apricot, olive, pome and stone fruits, nut cultivars, ornamental plants for indoor and outdoor plantation, cut flower plants, etc. We have a modern plant tissue culture laboratory complete with high-tech machineries such as laminar flow hoods, plant growth chambers, etc. which produce millions of tissue culture rootstocks with paramount quality each year.



Advantages of tissue cultured plants over conventional propagation methods employing offshoot planting

- Rapid introduction of new varieties
- Production of disease-free stock
- Year round propagation
- Improved uniformity of plant material
- Long term storage of valuable germplasm
- Excellent establishment rates in the field
- Superb fruiting after only 3-4 years
- Improved yields
- Easy and efficient international transfer of germplasm in terms of volume, weight, and health status

## Phosphate Biofertilizer BARVAR-2™

BARVAR-2 phosphate biofertilizer contains two types of Phosphate Solubilizing Bacteria (PSB) that hydrolyze organic phosphate compounds in the soil making phosphate ion available to plants.

### Features and Advantages

- High Phosphate solubilizing competence
- Genetically stable
- Environmentally safe
- Safe for human, animal, and plants
- Colony formation in rhizosphere
- Long shelving time
- Simple application methods
- Inexpensive shipping; compatibility with other chemicals
- Reduction of environmental pollution caused by chemical fertilizers
- Reduces the occurrence of soil-borne diseases
- Improves the soil structure
- Significantly increases the yield

In practice, Barvar biofertilizers consistently increase the yield of crops and fruit trees by 10 to 50 percent; while reducing the need for chemical phosphate fertilizer by over 50 percent.

### AzotoBarvar-1™ Biofertilizer

AzotoBarvar-1, as a replacement of nitrogenous chemical fertilizer like urea, is made of a free-living azotobacterium that converts atmospheric nitrogen to ammonia. The bacterial strain tolerates high salt, high temperature, and a wide range of pH.



### **Features and Advantages**

- High nitrogen fixation capability
- Genetically stable
- Environmentally safe
- Safe for human, animal, and plants
- Colony formation in rhizosphere
- Long shelving time
- Simple application methods
- Inexpensive shipping; compatibility with other chemicals
- Reduction of environmental pollution caused by chemical fertilizers
- Reduces the occurrence of soil-borne diseases
- Improves the soil structure
- Significantly increases the yield

### **NitroKARA™ Biofertilizer**

NitroKara is a nitrogen fixing biofertilizer that consists of a highly efficient nitrogen fixing bacteria called Azorhizobium caulinodans which was isolated from nature. Azorhizobium caulinodans produces growth promoting substances such as Indole Acetic Acid (IAA) and Gibberellins which promote root proliferation thereby increasing rootlet density and root branching.

### **Features and Advantages**

- Non chemical composition
- Efficiency of 1 kg or 1 litre of KARA biofertilizer is equal to 100 kg of urea fertilizer
- Reduces the need for artificial chemicals in fields and gardens
- Eco-friendly and poses no danger to the environment
- Increases water use efficiency
- Promotes the growth of plants
- Enhances seed germination and plant growth
- Increases the crops yield
- Provides protection against drought and certain soil borne diseases
- Improves soil structure and water holding capacity
- Restores natural soil fertility
- Safe for humans, pets, and wildlife

## Agricultural Biotechnology Equipment

There are companies with over 20 years of strong experience that in cooperation with scientists from different related fields of research are leaders in the design, manufacture, and installation of controlled environment systems that provide precise temperature, humidity, and light conditions for agricultural and pharmaceutical research needs including controlled temperature and humidity chambers (plant growth and tissue culture), photo stability rooms and chambers, incubators, germinators, and research greenhouses, etc.



## 2.8 Some Other Iranian Biotechnology Achievements

Apart from the previously mentioned advances and achievements, Iran has excelled in many other fields of biotechnology (Table 2-2).

Table 2-2 Some other Iranian biotechnology achievements

<b>Biotechnology Field</b>	<b>Achievements</b>
Biopharmaceutics	Interferon alpha (IFN- $\alpha$ )
	Granulocyte Colony-Stimulating Factor (GCSF)
	Peginterferon alfa (peg- $\text{INF } \alpha$ )
	Erythropoietin
	Growth hormone
	Antineoplastic
	Recombinant Hepatitis b Vaccine
Biomedicine	Detection Kit ELISA and PCR base, HCV, HBS, HIV
	Schwann cell therapy of spinal cord injury and stem cell therapy for other diseases
	Bone marrow transplant for more than 2500 patients
	Establishment of early detection center networks and medical genetics within the country and development of genetic detection methods
Bio-Agriculture	Production of a variety of veterinarian Vaccines such as Foot and Mouth Vaccine
	Phosphate and Nitrate Bio-fertilizer
	Plant tissue culture such as date palm, banana, grapes, GF root stocks, strawberry, apple root stocks, and ornamentals
	Production of bio-pesticides, bio-insecticides, bio-fungicides, and bio-herbicides
	Production of Xanthan
	Biological Desludging of crude oil tanks
	Production of Cell Culture media
	Membrane Bioreactor for Wastewater Treatment
	Biological Control of Corrosion

# 3. Nanotechnology

## 3.1 Introduction

Upon realizing the significant influence of nanotechnology on Iran's future economy, extensive activities were initiated in 2000. In this respect, the center for Innovation and Technology Cooperation (CITC) set up a "nanotech policy study committee" in 2001 with the aim of devising a national road map to take advantage of the benefits of this important technology. Meanwhile, numerous measures such as holding various forums, seminars, and publication of newsletters were carried out by CITC between 2001 and 2002 which led to the establishment of, Iran Nanotechnology Initiative Council (INIC) in 2003.

## 3.2 Iran Main Nanotechnology Actors

The main organizations involved in nanotechnology policy making and implementation in Iran are introduced below.

- **Iran Nanotechnology Initiative Council**

Iran Nanotechnology Initiative Council (INIC) was founded in 2003 in order to promote nanotechnology in the country. INIC has a number of sectors that incorporate key players in the field of nanotechnology including research, education, industry, investment, and policy making bodies. Currently, INIC is running under the Iranian vice-presidency in Science and Technology. Figure 3-1 illustrates the organisational structure of INIC:

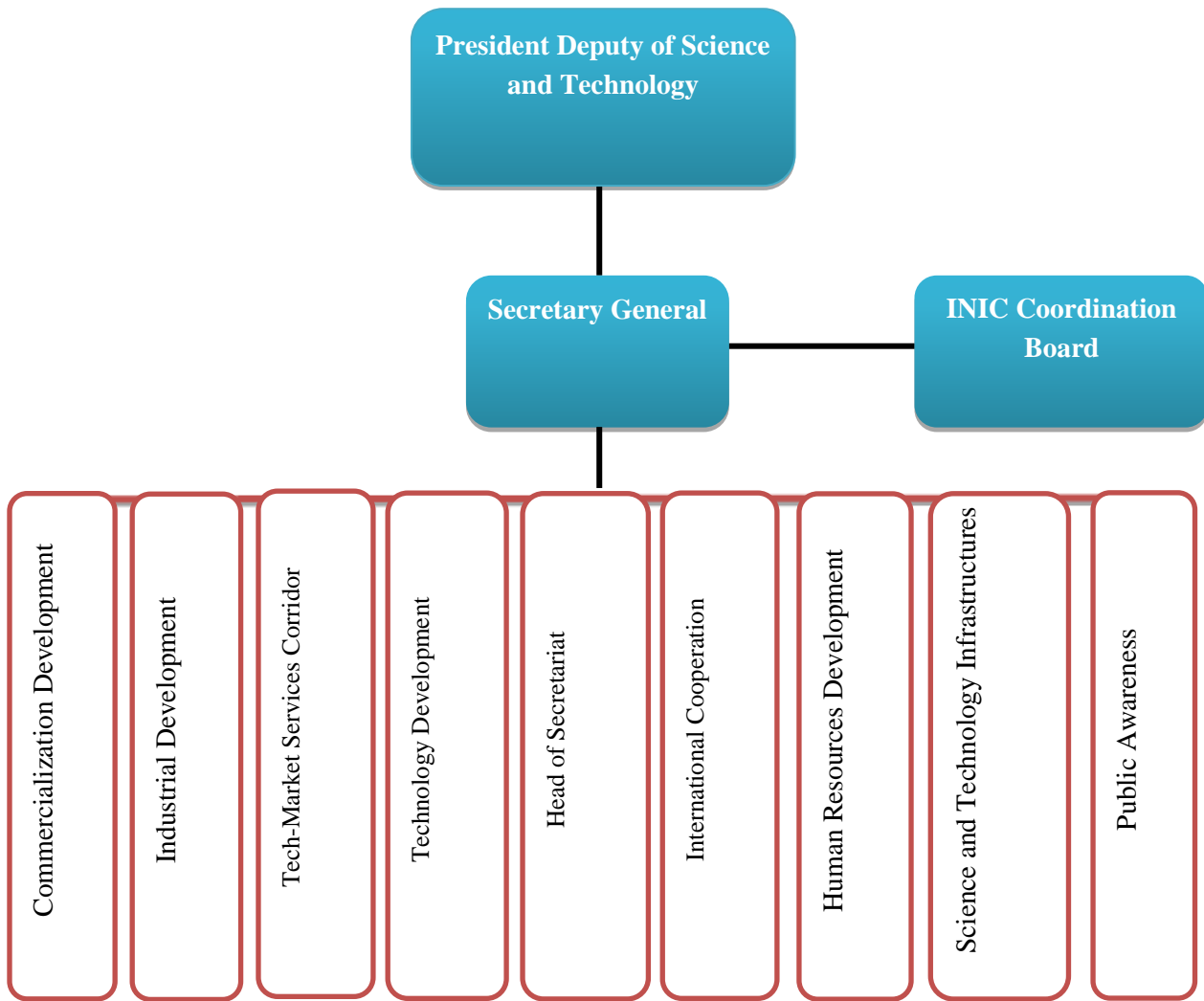

Figure 3-1 INIC organisational structure

INIC has taken several key measures for promoting international cooperation, including:

- Establishment of the regional network ECO-NANO with 10 member countries
- Establishment of the International Centre for Nanotechnology in Iran, in association with UNIDO
- Active participation in (the periodical meetings of) the International Nanotechnology Standardization Committee (ISO/TC229)
- Membership in Asian Nano Forum (ANF)

- **Iran Nanotechnology Laboratory Network (INLN)**

Iran Nanotechnology Laboratory Network (INLN) was established in 2004 to facilitate access to necessary technological infrastructures and laboratory services for academic and industrial researchers. The network was established considering the importance of EHS<sup>1</sup>-related issues to nanotech products. This network has 42 laboratory complex members of both public and private sectors in 11 provinces.

- **Iran Nanotechnology Standardization Committee**

Iran Nanotechnology Standardization Committee or ISIRI/TC229 technical committee was established in 2006 with the partnerships of Institute of Standard and Industrial Research of Iran (ISIRI) and Iran Nanotechnology Initiative Council (INIC). Since its inception, this committee has been a member of international Committee for Standardization (ISO/TC229). The main aims of the committee based on our country's priorities are as follows:

- Developing a set of necessary standards for nanoproducts;
- Supporting the necessary infrastructures for implementing and monitoring the standards;
- Participating in the international initiatives for standardizing nanotechnology.

Iran Nanotechnology Standardization Committee is comprised of 3 specialized working groups (WG) as follows, in harmony with the ISO/TC299 committee:

- Terminology and definition;
- Measurement and characterization;
- Health, safety, and environment.

So far, a set of 15 national standards and 1 international standard have been released by this committee. Iran is also responsible for 2 other international standards which are currently in the preparation process in ISO/TC299. The main activities of the committee can be summarized as: communication and coordination with the relevant organizations for developing and monitoring the implementation of standards, supporting the development of national and international standards, educating; promoting; and developing the needed capacities in the field of standard and safety, as well as setting the country's priorities in this area.

---

<sup>1</sup> Environment, Health and Safety



- **Iran Nano Safety Network (INSN)**

The proposal for establishment of INSN was put forth by Nanotechnology Standardization Committee of INIC in early 2011. This network was set up to support safe and responsible development of nanotechnology in Iran. The goals of the network include:

- Developing a sustainable network of experts, researchers and industrial centres involved in health safety and environmental issues;
- Identifying national priorities in implementing the mission of the network and coordinating research activities of the member research centres;
- Setting up the necessary infrastructures for drafting national standards and domesticating international standards;
- Providing a support system for drafting rules and regulations concerning health, safety, and environmental friendliness of Nano products;
- Enhancing hardware and software capabilities of the country in relevant domains.

INSN has officially started to operate since 2012 and it is currently active in the areas of nanosafety public promotion, enforcement of standards and regulations, and development of necessary infrastructures.

INSN has provided a suitable environment for domestic researchers and relevant institutions to join the network in order to converge their activities in the context of specific plans managed by the network for development of standards, guidelines, and regulations for safety and environmental issues of nanotechnology. INSN has four working groups (WG) comprised of more than 40 academic members with a diverse range of expertise that include:

- Ethics
- Environmental Safety
- Healthcare
- Work Safety

### 3.3 Current Nanotechnology Status in Iran

Iran's growth in the field of nanotechnology has been remarkable. In 2000, Iran was ranked as the world's 59<sup>th</sup> country in terms of science generation for which an important index is the number of ISI papers published in various well known international peer reviewed journals. However, it only took a decade for Iran's nanotechnology to achieve 8<sup>th</sup> rank in 2012 (Figure 3-2). Since 2004, Iran has had the highest rate of growth in this field among leading countries of the world in this field.

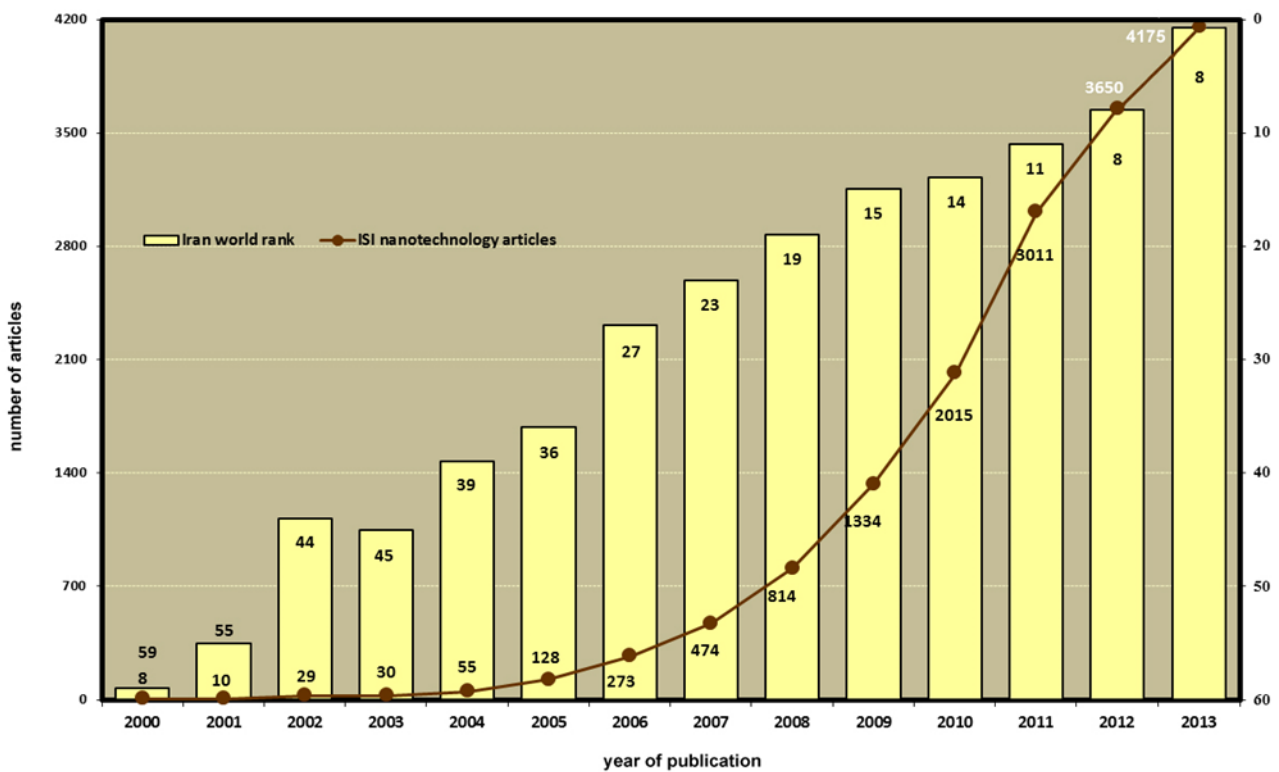

Figure 3-2 Iran's international ranking for nanotechnology articles in the period 2000-2012

In 2013, Iran ranked 8<sup>th</sup> in the world, 5<sup>th</sup> in Asia and 1<sup>st</sup> among the Islamic countries in the field of nanotechnology publications (table 3-1).

Table 3-1 Top 30 countries by published nano-articles in 2013

Rank	Country	Nano-article	Share	Rank	Country	Nano-article	Share
1	China	31,329	30.00%	16	Singapore	1,940	1.86%
2	USA	19,053	18.25%	17	Brazil	1,628	1.56%
3	India	7,103	6.80%	18	Poland	1,488	1.43%
4	South Korea	6,664	6.38%	19	Netherlands	1,375	1.32%
5	Germany	6,531	6.25%	20	Switzerland	1,370	1.31%
6	Japan	6,348	6.08%	21	Turkey	1,252	1.20%
7	France	4,596	4.40%	22	Sweden	1,234	1.18%
8	Iran	4,175	4.00%	23	Malaysia	1,093	1.05%
9	UK or England	3,565	3.41%	24	Saudi Arabia	1,088	1.04%
10	Spain	3,271	3.13%	25	Belgium	1,035	0.99%
11	Italy	3,210	3.07%	26	Mexico	847	0.81%
12	Taiwan	3,121	2.99%	27	Portugal	843	0.81%
13	Russia	2,774	2.66%	28	Egypt	770	0.74%
14	Canada	2,509	2.40%	29	Romania	769	0.74%
15	Australia	2,431	2.33%	30	Israel	738	0.71%

Table 3-2 Contribution of Iran's Nano articles compared to total ISI articles in countries with more than 500 ISI articles in 2012

<b>Rank</b>	<b>Country</b>	<b>Total country records</b>	<b>% of all country records</b>
1	Singapore	9941	19.97
2	Iran	21651	16.86
3	China	175746	16.1
4	South Korea	46029	14.92
5	India	43849	13.86
6	Saudi Arabia	6664	13.78
7	Ukraine	4797	12.67
8	Malaysia	7592	12.18
9	Taiwan	25851	11.93
10	Romania	6410	11.58
11	Russia	25810	11.12
12	Egypt	6532	10.07
13	Japan	71800	9.33
14	Germany	89581	7.78
15	France	62210	7.73
16	Ireland	8458	7.53
17	Poland	19845	7.41
18	Portugal	10900	7.28
19	Czech Republic	9221	7.22
20	Spain	48350	7.09

**“This position has been achieved through contributions of more than 98 universities and research institutes with over 15246 researchers/scientists with graduate degrees that are involved in nanotechnology research “(Table 3-3).**

Table 3-3 Iran nanotechnology statistics (2013)

Items	Total No
Researchers / Scientists	17499 Scientists 2565 Faculty members
Universities Running Ph.D. Programs	15
Universities Running M.Sc. Programs	34
Universities and Research Institutes Involved	103
No. of Post Graduates (last Update 06/30/2013)	8237
Ph.D. Projects	1312 Finished projects 1369 Ongoing projects
M.Sc. Projects	8125 Finished projects 4398 Ongoing projects
Published Books	126 National 32 International
ISI Publications (2000-2013)	16006
International Patents	119
Nanotech Laboratories	57
Start-up Companies	104
SME's / Large Scale Companies	258

### 3.4 Nanotechnology Priorities

Some of the key national priorities set for nanotechnology advancement in Iran include (but are not limited to):

- Energy (oil, gas & petrochemicals, solar cells);
- Health (DDS & diagnostic kits);
- Water and Environment;
- Construction.

### 3.5 Iranian Nanotechnology Companies

More than 370 companies are active in different fields of nanotechnology in Iran, among which 103 are settled in incubators. Among the above mentioned 370 companies, 237 produce nanotechnology products, 25 produce laboratory equipment, 72 are services companies, and 36 are commercial companies. Figure 3-3 represents a sum of 262 manufacturing and equipment manufacturing companies by their industrial fields.

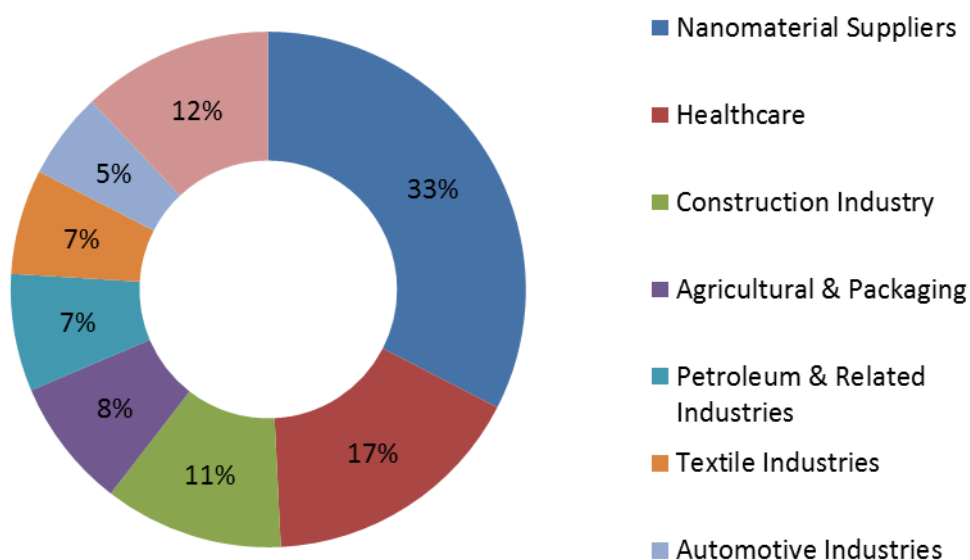

Figure 3-3: Distribution of areas of activities of nanotechnology companies in Iran

Table 3-4 Iran's nanotechnology instruments and products in various industrial sectors

Industrial Field	Product
Agriculture	Ethylene Nano-Absorbent Granule
Automotive & Petroleum	Copper – Alumina Nano-Composite
	Metallic Nano – Fluid
	Pt-Re/ $Al_2O_3$ Nano-Catalyst
	Naphtha Reforming Catalyst (I-109)
Health & Medicine	Silver Nano-Colloid
	Anti-Microbial Wound Rinsing Spray
	Silver Nano-Colloid
	Anti-Microbial Colloid
	Anti-Cancer Drug SinaDOXOSOME
	Doxorubicin HCl Liposome Injection 2mg/ml
Paint	Resin/Clay Nano-Composite
	Self-Cleaning Acrylic Paint
Raw & Building Materials	Three-Ply Silent Pipe
	Silica Nano-Powder
	Silica Aerogel Powder
	Alumina Nano-Powder
Textiles & Polymer	Nylon Fibre Containing Nano-Silver
	Cellulose Nano-Fibres Suspension
Instruments (Analytical Systems)	Capillary Electrophoresis (CE)
	Mass Spectroscopy (MS-TOF)
	Differential Thermal Analysis (DTA)
	Nano SORD
	Ion Mobility Spectrometer (IMS)
	Gas generator (GC)
	Two Dimensional Gas Chromatography (GC*GC)
Instruments (Nanotechnology)	Plasma Nano Colloid Maker (PNC)
	Pulse Electrical Explosion Maker (PEE)
	Deep Reactive Ion Etching (DRIE) "SI-HV300"
	Ultrasonic Homogenizer
	Nano Cavitation
	Freeze Dryer
	Vacuum Hot Press
	Electrospinning
Instruments (Magnetometer)	Vibrating Sample Magnetometer (VSM)
Instruments (Scanning Probe Microscope)	ARA-AFM
	NAMA-STM
	Atomic Force Microscopy (AFM)

<b>Industrial Field</b>	<b>Product</b>
Instruments (Deposition Systems)	Sputter coater & thermal evaporation ( medium vacuum)
	PECVD-RIE system
	Vacuum Melt Spinner
	Pulsed Laser Deposition System (Model: LTS)
	Vacuum RF & DC Magnetron Sputtering System (Model: MSS)
	High Vacuum Evaporation Systems (Model: ETS-160, EDS-160)
	Plasma Enhanced Chemical Vapor Deposition (PECVD) systems
	Vacuum Sputtering and Evaporation Systems
	Plasma Assisted Chemical Vapor (PACVD) Deposition systems
	Desk Sputter Coater System (Desktop Sputtering)
	Langmuir-Blodgett Films, Coating Equipment
	Thin Film Deposition Systems (VCST-Series)
	Chemical Vapor Deposition (CVD)
Instruments (Imaging Systems)	High Resolution Animal SPECT Imaging System
	Fluorescence Molecular Imaging
Instruments (Accessories)	Digital Imaging System for High Energy Beam Images

Further details about some of the above products are presented below.

### **Anti-Cancer Drug SinaDoxosome**

Doxorubicin HCl is a drug that is commonly used in the treatment of a wide range of cancers, including haematological malignancies, different types of carcinoma, and soft tissue sarcomas. Doxorubicin's most serious adverse effect can be life-threatening heart damage, which limits its application. Therefore, various efforts have been made to reduce this side effect, including encapsulating it in nanoparticle systems such as nanoliposomes. This Nano medicine is used in the treatment of ovarian cancer, breast cancer, multiple myeloma, and Kaposi sarcoma associated with AIDS. It is also in the clinical trial phase for some other cancers.



SinaDoxosome has successfully passed all the required animal and human trials and received the necessary license and certificates, therefore allowing its administration in local hospitals. SinaDoxosome is expected to be introduced to the international market in the near future.

### Features

- The polyethylene glycol coating (stealth polymer) reduces the uptake of liposomes by RES cells and therefore increases the life span of liposomes in blood (half-life about 53 hours)
- The particle diameter of approximately 100 nm enables the nanoparticles to target the tumour tissues by enhanced permeation and retention mechanisms
- The lipid matrix with high phase transition temperature and low permeability provides stable encapsulation of the doxorubicin in nanoliposomes and the internal aqueous buffer phase provides high loading efficiency for Doxorubicin



Anti-Cancer Drug SinaDoxosome

### Scanning Tunneling Microscope (STM)

A scanning tunneling microscope is a powerful tool for obtaining micrographs from conductive and semi conductive materials. The imaging technique has recently been improved for microscopy of nanostructured biomaterials on highly ordered atomic surfaces.

Scanning Tunneling Microscope (STM)  
Comparison of 3D image of a single antibody protein scanned by NAMA-STM with the theoretical stimulation

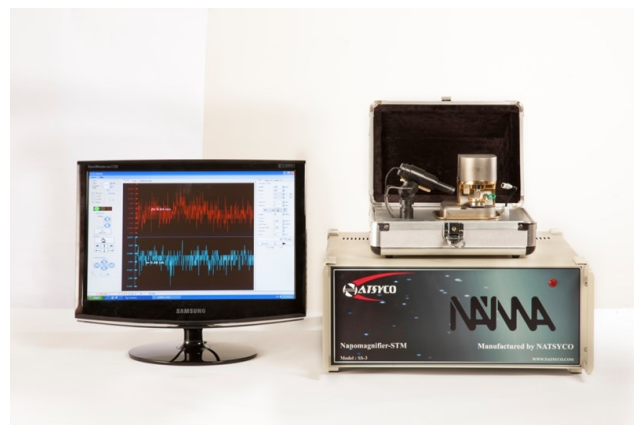

Scanning Tunneling Microscope (STM)



Comparison of 3D image of a single antibody protein scanned by NAMA-STM with the theoretical stimulation

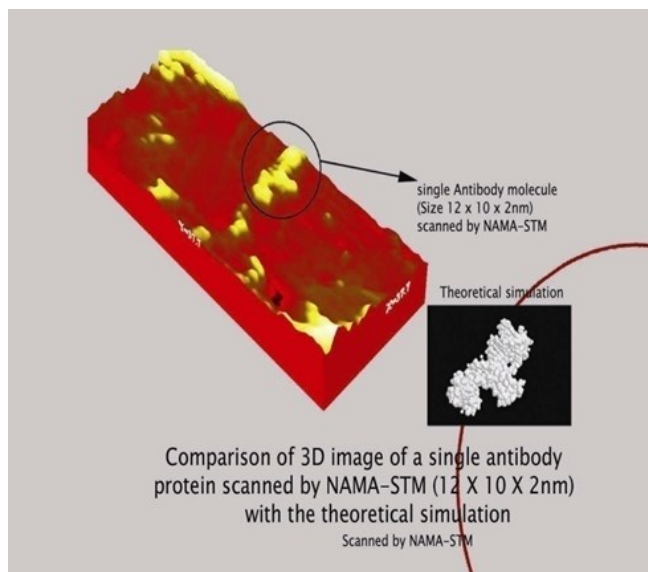

## Applications

- Atomic topological study of conductive and semi-conductive surfaces like metals or even biological molecules such as DNA or antibody
- Providing clear, accurate, and reproducible 2D and 3D images in the nanometer scale

## Deep Reactive Ion Etching (DRIE)

One of the most applicable methods in plasma phase etching is reactive ion etching (RIE). Dry etching which is used in RIE uses reactive ions in an RF plasma environment to bombard the sample and etches it with both chemical and physical methods. The new proposed system can make vertical and deep Micro and Nano structures with excess of 100 aspect ratio and vertical etching rate of 700 nm/min. Unique patterns can be obtained using the proper gas, without the intervention of polymers. This device is an improved DRIE.

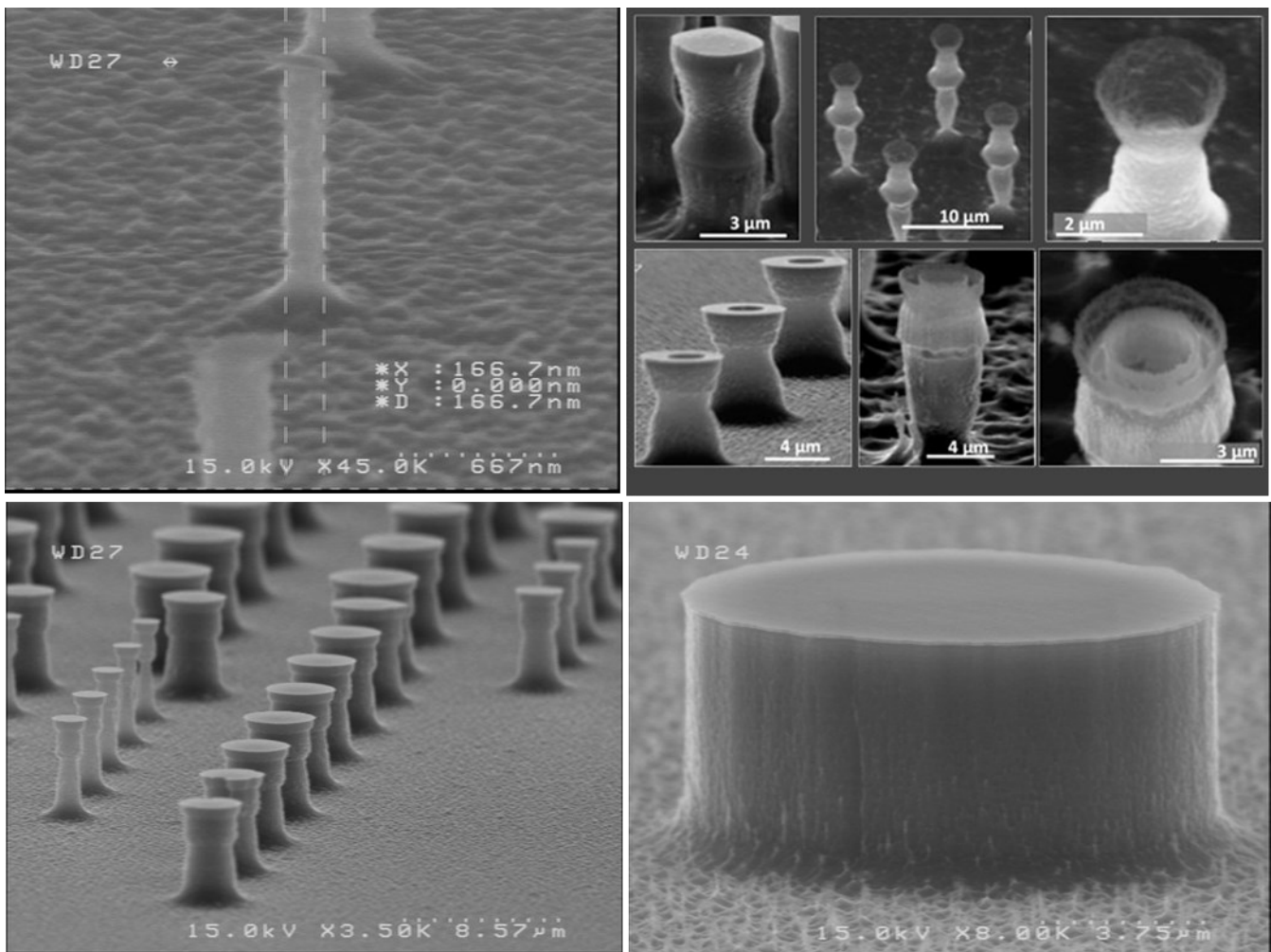

FESEM image of micro and nano-structures etched by DRIE

Along with rapid progress in Nano-science, filtration industries and medical instruments, companies have begun to apply nanotechnology in manufacturing masks and band aids. Industrial Electroris can easily meet the requirements of today's high-tech sector and it is expected to have a good market in Nano-fiber related industries.



Industrial Electroris Machine for the production of large scale nanofiber filters

## Applications

- Filtration in power plants and automotive industries;
- Producing band aids, masks, and scaffolds in biomedical industries; Removing heavy metals in water purification industry.

## High Resolution Animal SPECT Imaging System

HiReSPECT is a Dual Head Small Animal SPECT (Single Photon Emission Computed Tomography) imaging system that provides high resolution in vivo three-dimensional (3-D) images of physiological functions in small animals used for experimental studies.

The technique requires injection of a gamma-emitting radionuclide into the bloodstream of mice. SPECT imaging is performed by using a gamma ray detector to acquire multiple 2-D images from multiple angles in 360°. Computer software is then used to apply a tomographic reconstruction algorithm to the 2-D images, yielding a 3-D dataset of distribution of the radionuclide.



High Resolution Animal SPECT Imaging System

### Applications

Small animal imaging is an emerging field which is of great value to various biomedical research areas such as neurology, oncology, cardiology, immunology, and infection biology. The pharmaceutical industries and research centers will profit from SPECT systems as they have the potential to accelerate drug and biomarker development by yielding more reliable in vivo results and cost effective study designs.

## **Ion Mobility Spectroscopy (IMS)**

Ion mobility Spectroscopy (IMS) is a new technology which is utilized for identifying small quantities of chemical materials. This technique is similar to TOF Mass Spectroscopy, except that it works at atmospheric pressure. Ions are allowed to enter the spectrometer using a carrier gas and then charged using an ionizer source. Ions travel through an electric field and are identified with respect to their speed. The speed by which ions travel in the drift tube is dependent on the Ion mobility which is an intrinsic property related to mass, size, and shape of ions.

### **Applications**

- Security : detection of explosives and drugs;
- Fundamental research
- Analytical chemistry: determination of trace amounts of chemicals in different matrices such as: blood plasma, saliva, breath, chewing gum, chicken meat, tablets, syrups, etc.;
- Instrumentation: Characterization of different atmospheric pressure ionization sources.

Ion Mobility Spectroscopy (IMS) as a drug detector



## Plasma Enhanced Chemical Vapor Deposition (PECVD)

Plasma Enhanced Chemical Vapor Deposition unit is a highly specialized piece of equipment for the deposition of carbon nano-structures, carbon nano-tubes, and nano-structure fabrication. SI-PE803 is a newly developed collection of three reactors, which enables the user to program the growth process by means of computerized control over growth parameters such as temperature, pressure, plasma power (if needed), and the sequence of gas inclusion into the system. The standard unit comes with two lines of hydrogen and acetylene, although it can be upgraded by addition of one or two extra MFCs to include other gases, such as oxygen,  $\text{NH}_3$ , or a carrier gas.



Plasma Enhanced Chemical Vapor Deposition (PECVD) Systems

### Applications

- Apart from standard growth, which is expected from a CVD reactor, this piece of equipment can be used as a reactive ion etching unit for hard-to-etch substrates such as SiC
- Production of carbon nano-structures

## Sputtering & Etching Systems

Sputtering is a process whereby atoms are ejected from a solid target material due to bombardment of the target by energetic particles. It is commonly used for thin-film deposition, etching and analytical techniques. DC magnetron sputtering system is one of the most commonly used methods for thin layer deposition. In this process, a very low pressure, usually around  $10^{-8}$  Torr is required.

Available deposition techniques include:

- DC magnetron sputtering
- RF magnetron sputtering
- Resistive thermal evaporation



### Applications

- Anti-reflective coating
- Semiconductors
- Compact disc master metallization
- Dielectrics
- Organics, polymers, and OLEDs
- Photonics research
- Solar cells



## Plasma Assisted Chemical Vapor Deposition (PACVD)

Chemical vapor deposition (CVD) is carried out at around 900°C and is therefore applicable to a narrow range of materials such as very special steels that can withstand the high treatment temperatures as well as some cermet materials. Using plasma in Plasma Assisted Chemical Vapor Deposition (PACVD) enables the process to be carried out at temperatures as low as 500°C, allowing the process to be applied to a vast range of steels and some other metallic and non-metallic components. Owing to the unique properties of the coatings produced by this method (e.g. TiN, TiC, etc) such as high hardness and strength, high wear and corrosion resistance, very good adhesion of the coating to substrates, etc., the quality and performance as well as value of the coated components are increased.



### Applications

To increase durability, reduce release agent requirement, and extend working life by about 500% in:

- Casting molds;
- Extrusion Dies;
- Plastic molds;
- Forming tools;
- Cutting tools;
- Tools coating;
- Automotive components;
- Decorative.

### **Portable water production by Nanofiltration**

This product is a 20 feet container for desalination and biological filtration of water reservoirs. Quality control and quality assurance of this product is performed according to WHO standards for drinking water. It is worth mentioning that the system has already been used successfully in one of the small cities in southern Iran (Mollasani) for the production of clean and safe drinking water. This product is capable of filtering up to 60m<sup>3</sup> of water a day.





# 4. Energy

## Part One: Conventional Energies (Oil & Gas)

### 4.1.1 Introduction

In this section, after a review on Iran's current status in oil and gas (reservoirs, production, exports, etc.), the major oil R&D organisation in Iran, i.e. Research Institute of Petroleum Industry is briefly introduced followed by presentation of some of Iranian's major achievements in oil & gas technologies.

### 4.1.2 Current Conventional Energies (Oil & Gas) Status in Iran

Iran holds the world's fourth-largest proven oil reserves and the world's second-largest natural gas reserves [US eia]. Iran's proven crude oil reserves in 2012 were 157,300 million barrels which makes it the second country in the Middle East in this regard. Iran's proven natural gas reserves in 2012 were 33,780 billion standard cubic meters which made it the leading country in the Middle East with the highest proven natural gas reserves. [OPEC statistics]

Figures 4-1 and 4-2 illustrate the oil and gas reservoirs of Iran in comparison to the world's largest oil and gas holders, respectively<sup>1</sup>.

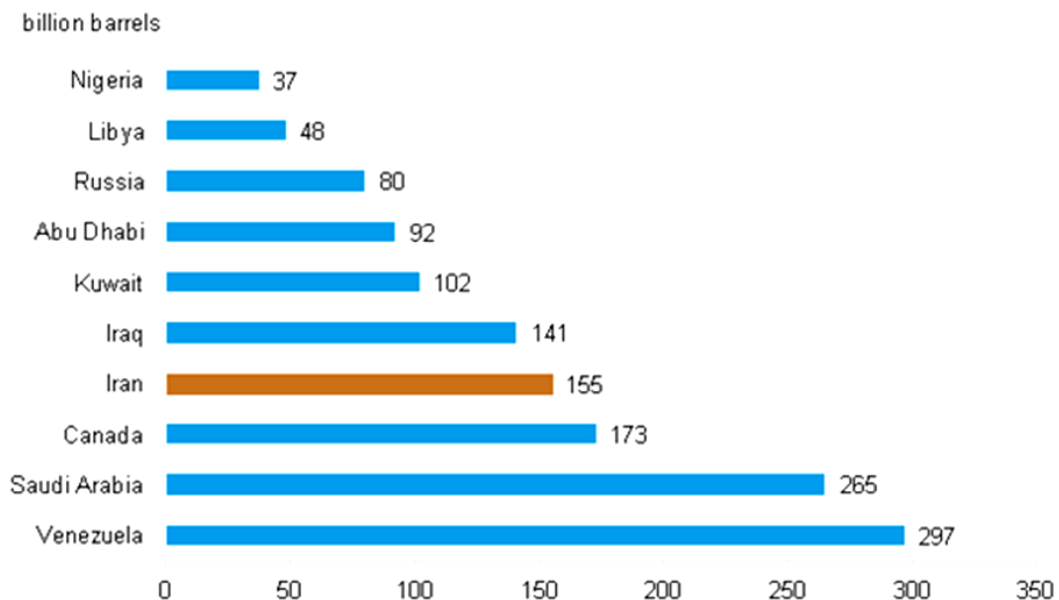

Figure 4-1 Largest proven reserve holders of oil, January 2013

<sup>1</sup> <http://www.eia.gov/countries/index.cfm?topL=exp>

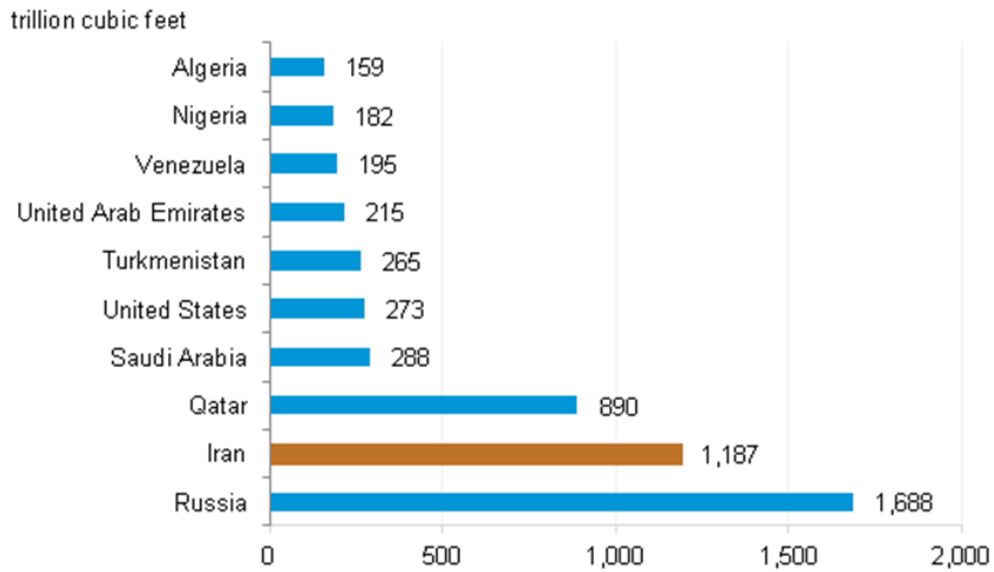

Figure 4-2 Largest proven reserve holders of natural gas, January 2013

Iran holds around 10% of the world's proven oil reserves and 16% of the world's proven natural gas reservoirs, as indicated in figures 4-3 and 4-4 indicate

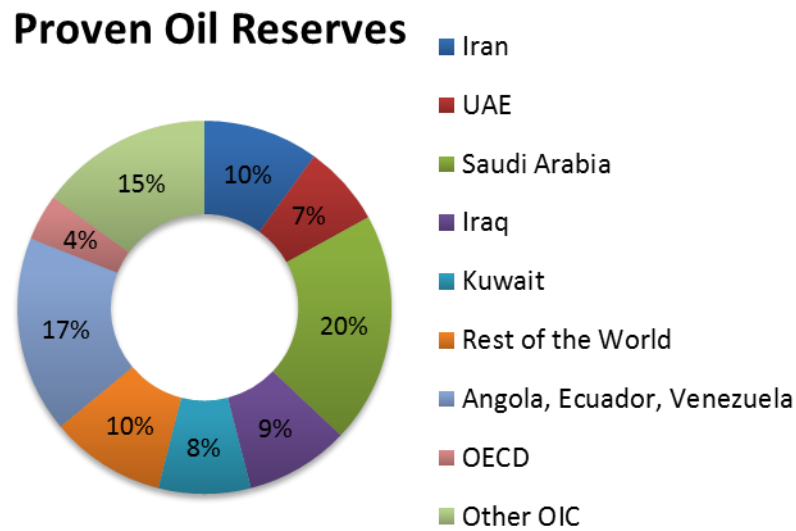

Figure 4-3 Proven crude oil reservoirs, % of world total, 2009

## Proven Gas Reserves

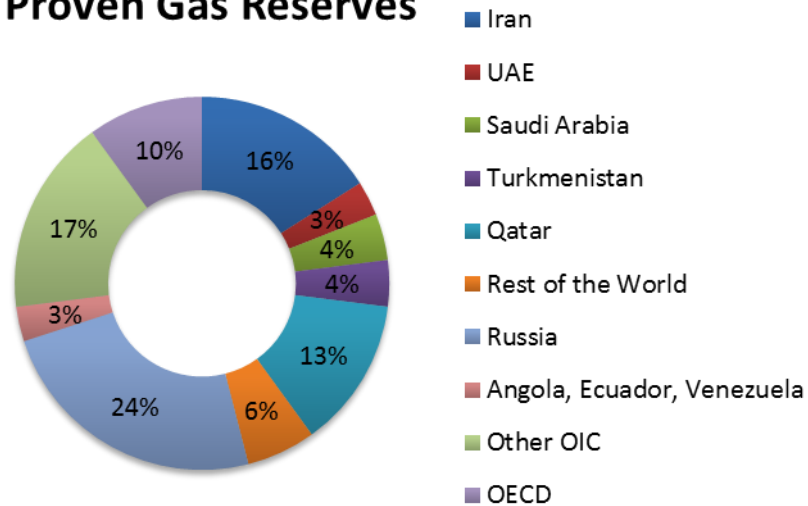

Figure 4-4 Proven natural gas reservoirs, % of world total, 2009

In terms of oil production, Iran ranked fourth in the world after Saudi Arabia, the Russian Federation and the United States in 2011, and was the fourth country in the world in the field of oil net export. Iran was also the fifth biggest gas producer in 2011. (IEA)

Figure 4-5 shows that Iran held 13.1% of the OPEC proven oil reservoirs in 2012.

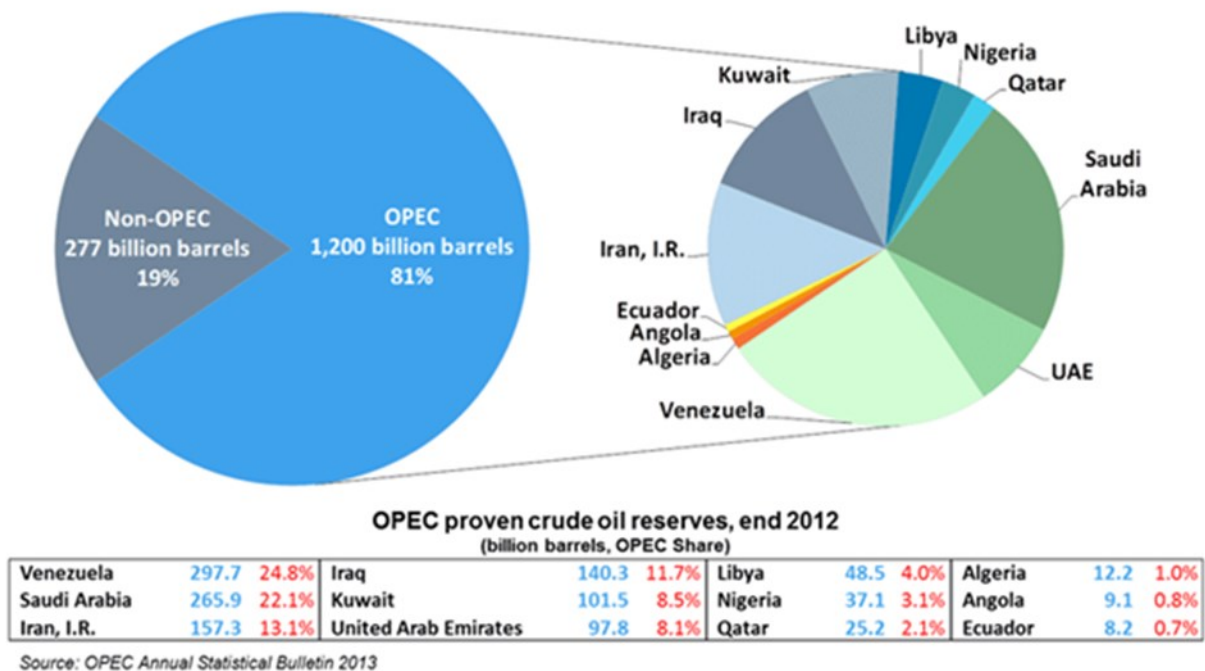

Figure 4-5 OPEC share of world crude oil reserves, 2012<sup>1</sup>

<sup>1</sup> OPEC Website

Currently, Iran has 40 producing fields, 27 onshore and 13 offshore, with the majority of crude oil reserves located in south western Khuzestan.

In the next section, the leading petroleum research organization in Iran will be briefly introduced

#### **4.1.3 Research Institute of Petroleum Industry (RIPI)**

Research Institute of Petroleum Industry (RIPI) is a leading research organization that is involved in a wide range of research activities as well as providing laboratory, technical, and consulting services for oil, gas and petrochemical industries. Established in 1959, throughout the years RIPI underwent many transformations in its R&D activities and has become a major technology provider for Iran's petroleum industry.

**“The institute has established a reputation for technical excellence and is dedicated to helping its clients enhance the value of their existing assets”.**

RIPI is the main R&D organization in Iran's oil industry and is the largest of its kind in the Middle East. It also provides the industry with services to maximize profits. RIPI identifies the bottlenecks and helps implement and sustain value enhancing solutions for long term profit improvement. Main fields of technology development at RIPI include synthesis of gas, production of gasoline by bi-functional iron based catalysts, and production of mid-distillates by cobalt based catalysts.

[<http://www.wipo.int/ipadvantage/en/details.jsp?id=2904>]

In the next section, some of major Iranian achievements in the field of conventional energies are introduced.

[<http://www.wipo.int/ipadvantage/en/details.jsp?id=2904>]

In the next section, some of major Iranian achievements in the field of conventional energies are introduced.

#### 4.1.4 Major Iranian Achievements in Oil & Gas Technologies

##### Demercaptanization of Petroleum Fractions (DMD Process)

In DMD process, by using caustic solutions, light mercaptans, H<sub>2</sub>S, COS, and CS<sub>2</sub> are removed from petroleum fractions, and corrosive and active heavy mercaptans are converted into disulfides.

Different types of DMD processes have been developed based on the type of petroleum fractions, the percentage of mercaptan present in the feedstock, and final products.



##### Different types of DMD processes include

- DMD-1: used in the demercaptanization of kerosene;
- DMD-2: used to produce odorant (pure mercaptan) from LPG and light naphtha;
- DMD-2k: recommended in demercaptanization of propane and butane;
- DMD-3: used in demercaptanization of heavy naphtha and gasoline fractions.

##### Demercaptanization of Crude Oil and Gas Condensates (DMC Process)

In this process, by using caustic solutions with a density of 5-15%, H<sub>2</sub>S, CS<sub>2</sub>, and light mercaptans are removed and heavy, active mercaptans are converted into stable non-toxic alkaline compounds.

##### Different types of DMC Processes include

- DMC-1: This process is used to reduce mercaptans and acidity of petroleum crude oil and gas condensates
- DMC-1M: In this process, the level of H<sub>2</sub>S in petroleum crude oil decreases from 100ppm to 5ppm and for light mercaptans (C<sub>1</sub>-C<sub>2</sub>), decreases from 300ppm to 20ppm
- DMC-2: In this process, light mercaptans (C<sub>1</sub>-C<sub>2</sub>) in petroleum crude oil decrease from 2000ppm to 20 ppm
- DMC-3: In this process, H<sub>2</sub>S decreases to 5 ppm, and the mercaptans in petroleum crude oil and gas condensates decrease from 4000ppm to 50ppm



### **n- Pentane Process**

This technology is used for separating different fractions of hydrocarbons to obtain a variety of solvents, a process that is based on two distillation columns in which light and heavy parts of LSRG are separated.



### **SULFIRAN Process**

This technology includes a single stage process for removing H<sub>2</sub>S from gas streams and converting it to innocuous elemental sulfur by liquid Redox (Reduction-Oxidation) reaction.



#### **Advantages of SULFIRAN process**

- Has a 99+% H<sub>2</sub>S removal efficiency
- Makes use of iron chelate catalyst, licensed by RIPI
- High flexibility and applicable in a wide variety of H<sub>2</sub>S containing gases
- Contains a catalyst which continuously regenerates in an oxidizer

### **Hydroconversion Technology**

Hydroconversion (HRH) is an innovative catalytic hydrocracking process that converts heavy and extra heavy crude to valuable crude. The main feature of this process is that it can break up high molecular hydrocarbons to obtain light and medium molecular hydrocarbons. This process is one of the most effective methods of upgrading heavy residues to obtain light products. The hydroconversion Process has certain advantages over the traditional hydrocracking process. This process has a high conversion rate (90% – 95%) and reduces the gravity of heavy crude from under 10 API to 30–35 API, however polymerization reactions do not occur and the quantity of asphaltene in the product is low.



## GTL

This technology is used for converting hydrocarbon gas to hydrocarbon liquid. Converting gas to liquid using the Fischer-Tropsch method is a multistep, energy consuming process that includes taking apart molecules of natural gas, predominantly methane, and reassembling them into long-chain molecules.



## ISOMIR Technology

Light Naphtha Isomerization

The Research Octane Number (RON) of light naphtha is around 70. Isomerization of this constituent can improve its octane number to around 90; therefore isomerization can be named as a RON booster.



### Advantages of ISOMIR Technology

- Compatibility with environment
- No chemical injection requirement to maintain catalyst activity
- Long catalyst service life
- Process simplicity
- No disposal problems
- High catalyst tolerance to feed stock impurities
- Optional feedstock pre-treatment

## Carbon Nanotubes Production Technology

RIPI has a CNT production technology and produces different grades of carbon nanotubes (CNTs) comprising single-walled nanotubes (F-CNT) in various diameters and purities.



### Advantages of Carbon Nanotubes Production Technology

- Production of single-walled, double-walled, and multi-walled carbon nanotubes with quality and purity
- Production of nanocatalyst for CNT growth
- Invention of continuous process for CNT production (EP1837306)
- Invention of nanocatalyst for CNT growth with high yield and quality (EP1782884)
- Invention of nanocatalyst based on CNT for gas conversion (EP1782885)
- Preparation of functionalized CNTs (Carboxyl, Amin, amide, Hydroxy groups)
- Application of CNTs as a nano-filter
- Application of CNTs as a catalyst support
- Application of CNTs as a gas adsorbent
- Bio application of CNTs
- Preparation of Soluble and dispersible CNTs in organic and aqueous media

### Methanol to propylene (PVM®)

Methanol to propylene transformation is a remarkable alternative for the production of propylene from natural gas, especially for countries with cost-advantaged feedstock supplies such as Iran which possesses the 2nd largest natural gas reservoirs in the world (1 million TCF, or 16% of the world's natural gas proved reservoirs). Production of propylene from methanol was developed by Petrochemical research and Technology Foundation (NPC-RT) using a Zeolite catalyst.



PVM demonstration plant with capacity of 1 ton/day methanol

### History of NPC-RT PVM® development

- PVM pilot plant with a production capacity of 1.5 kg/day methanol was set up in 1995
- PVM demonstration plant with a production capacity of 1 ton/day methanol was established in 2010
- Fanavaran and Sabzevar projects are based on NPC-RT MTP license

## **Polycarbonate**

Polycarbonate is a linear polymer which is synthesized from phosgene and bis-phenol A. It is an engineering polymer with high transparency and toughness which preserves its hardness at up to 140 °C and its toughness at -20°C. At present, polycarbonate is manufactured in Khuzestan Petrochemical Complex (KZPC). We are developing our technology for producing new grade and improving quality of the existing grade. We have also



developed in-depth research programs for designing newer technologies based on this technology.

## **Developing the technology for designing and manufacturing ball valves in high pressure class**

Industrial valves are one of the most important equipment used in petroleum and gas industries in Iran. These valves have high economic value and various applications for gas and liquid pipelines in oil and gas facilities such as refineries, gas gathering systems, and compression stations. Therefore, the variety of applications for this product has been considered seriously by industrial countries in the world.



## **Design and construction of gas turbine blades**

Turbine blades are important and applicable components of the turbine. Currently, we have the capability of manufacturing and quality control of raw materials (superalloys) as well as production of various types of gas turbine blades in the country.



## Part two: New & Renewable Energies

### 4.2.1 Introduction

The increasing growth of fossil fuel consumption along with consistent increase in environmental pollution is a major challenge in the field of energy management. Therefore, special attention has been devoted to reducing the amount of fossil fuel consumption and increasing the use of new and renewable energy in “the fifth socio-economic development plan”.

**“Renewable energy has a rich potential for job creation in different parts of the country, in areas such as construction and repair of large scale and micro-generation plants. Given the growing global concerns over energy insecurity and climate change, renewable energy technologies also have a strong export potential”.**

### 4.2.2 Renewable Energy Organization of Iran (SUNA)

Further to policies made by the Executive Director for Energy, Renewable Energy Organization of Iran (SUNA) was established in 1995 with the aim of achieving technological advances in connection with utilization of renewable energy resources, and assessing the potentials and execution of various projects (solar, wind and geothermal, hydrogen and biomass).

Iran's varied geography is well suited to a diverse and extensive set of renewable energy sources such as hydro, solar, wind, geothermal, biogas, hydrogen, and fuel cell energy.



Taleghan Renewable Energy Park: Center for H2 & FC technology demonstration and other types of renewable energy

## Hydro Energy

Iran has an estimated potential for hydroelectric power generation of between 23-42GW. By constructing the 7th hydroelectric power plant in Iran, the amount of power generation reached in excess of 8GW, which is more than all other power generation projects currently being developed. Iran plans to generate 14 GW of hydroelectric power by 2021, which will represent 20% of Iran's projected electrical capacity.

## Solar Energy

The potential for solar electricity generation in Iran is virtually limitless. Iran is quiet far from the tropic of Capricorn and most parts of the country are exposed to high levels of solar radiation with a daily average of between 5.0-5.4 KWh/m<sup>2</sup> in the south of the country (in comparison, London receives a daily dose of around 1.0 KWh/m<sup>2</sup>).

This gives an energy generating capacity of approximately 0.5 KW/m<sup>2</sup>, or 500 MW/km<sup>2</sup> for solar panels. The deserts of Iran occupy a quarter of the total land area; if only one per cent of the desert area was covered by solar PV collectors, the energy obtained would be five times more than the current annual electricity consumption in Iran.

## Achievements

Pilot implementation of Shiraz Solar thermal Power Plant with a capacity of 250 kilowatt as the biggest solar energy power plant in the Middle East, providing energy and electricity for rural areas using photo voltaic technology.

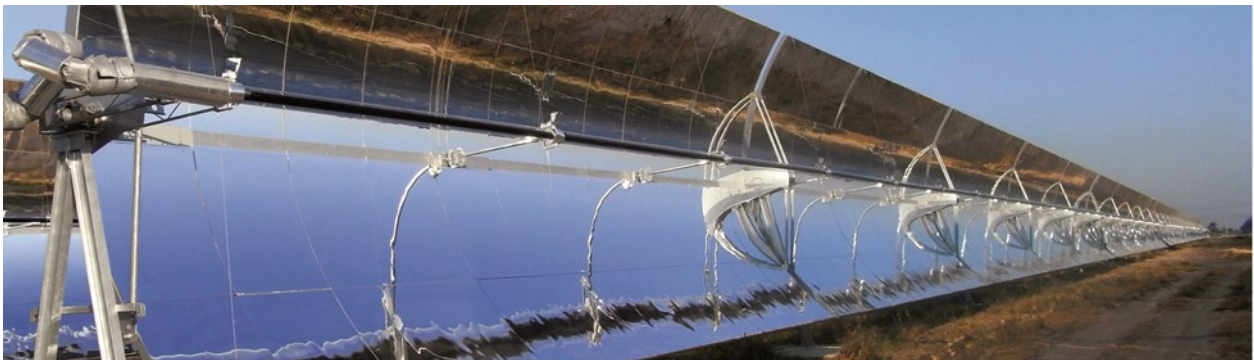

Shiraz Solar Parabolic Power Plant

## Wind Energy

Application of wind energy for electricity generation and water pumps holds a great deal of promise in the east of Iran. The wind potential has been studied in 45 experimental sites and it is estimated that there is a realistic prospective capacity of 6,500 MW.

According to the Iranian Wind Atlas, Iran has the potential to produce 140GW electricity. With regard to the existing wind power infrastructures, a minimum of 20-30% of this capacity can be achieved.

### Achievements

1. Setting up the production line for 660KW wind turbines
2. Constructing and launching wind power plants such as Manjil and Binalood with a capacity of 92 MW

## Geothermal Energy

Iran has substantial geothermal potential in both low and high grades. High grade geothermal energy is used to produce electricity, while low grade geothermal energy is used to supply heating and cooling. Considering the great geothermal potential in Iran, many efforts have been made to provide the necessary technologies for exploiting this energy. The technology of Borehole Thermal Response Test is one of Iran's achievements in this area. This test is used to determine heat conductivity, heat diffusivity, and heat gradients of geothermal boreholes. These parameters are necessary to design the exact size of ground heat exchanges, a technology that has been accomplished only by a few countries so far. Achievements worth mentioning in the field of biogas energy in Iran are the design and implementation of Mashhad Biogas Power Plant with a capacity of 600KW and of Shiraz Biogas Power Plant with a capacity of 1060KW.

Shiraz and Mashhad /biogas Power Plants



## Hydrogen and Fuel Cell Activities

With more than a decade of experience, Iran's hydrogen and fuel cell activities have brought up 50 R&D centres. Many projects are in production, storage, distribution, and consumption of hydrogen at laboratory and pilot scales. Other activities include:

1. Installing off-grid solar-hydrogen energy and fuel cell systems;
2. Manufacturing and testing hydrogen fuel cell cars;
3. Designing, constructing, and testing hydrogen storage vessels (100 bar, 20 m<sup>3</sup>);
4. Designing, manufacturing, testing, and installing a 200KW water electrolyzer with the capacity of 40Nm<sup>3</sup>/h of hydrogen.

### Achievements

- Designing and manufacturing a 5KW, 10KW polymer fuel cell
- Designing and manufacturing polymer fuel cell components; such as MEA, humidifier...
- Designing and manufacturing a single-cell solid oxide fuel cell, and 100W stack
- Ratification of a national strategic plan to develop fuel cell technology

### Clean Vehicles

Designing and prototyping the first Intelligent Electric Vehicle (iEV), and Intelligent Electric Fuel Cell Vehicle (iEFCV) on national platform, with the following specific features:

1. Maximum speed: 180Km/h;
2. Maximum range: 500Km for iEFCV, 250Km for iEV;
3. Battery type: lithium battery with BMS and on board charger;
4. Fuel cell capacity: 15KW;
5. High efficiency (energy consumption): 140Wh/km for iEV and 150Wh/Km for iEFCV;
6. Battery charging time with AITS is only 2-6 minutes;



5 KW polymer fuel cell manufactured by Isfahan Engineering Research Center



7. Unlade weight: 1240Kg for iEFCV, 1250Kg for iEV.

### Achievements

- Promoting the production technology of electric vehicles;
- Zero emission;
- Higher fuel economy;
- Economic profitability for the country due to lack of fuel consumption and prevention of pollution;
- Promoting cooperation between experts in Iran and abroad for the transfer of technology and technical knowledge



Intelligent Electric Vehicle



Intelligent Electric Fuel-Cell Vehicle

# 5. Advanced Materials (The case of Composites Technologies)

## 5.1 Introduction

Composites are made of various materials in different shapes and combinations. Their components preserve their properties and do not dissolve into each other. Production and consumption of advanced composite materials are increasingly growing in Iran. This growth is mainly due to the many advantages of these materials in comparison with conventional materials.

Nowadays, polymer based composites are used in a range of industries worldwide. Global statistics show an annual production of more than 7 million tons of composites which are applied in various industries. Advantages of polymer based composites such as simplicity in construction, light weight and at the same time high strength, simplicity of fault detection and maintenance, as well as high durability against corrosion play a major role in the production and application of these materials in different industries.

## 5.2 Current Status of Composites Technologies in Iran

Vast efforts have been made to remove major difficulties in different industries by means of advanced materials. Iranian scientists have come up with brilliant inventions in this area. A number of Iranian composite products have been developed from idea to market stage, commercialized, and are now serious competitors for similar foreign products.

The production and consumption of composites materials have increased from only 0.2 kg per capita in 1996 to more than 1.2 kg per capita in 2012, with the goal of reaching 3 kg per capita in the near future. This fast growth in usage and production is mainly due to the lightweight of these new materials and their good resistance against corrosion in comparison with conventional materials, which is a vital property especially in corrosive environments.

Figure 5-1 illustrates the growth of composites production and consumption in Iran during 1996-2012.

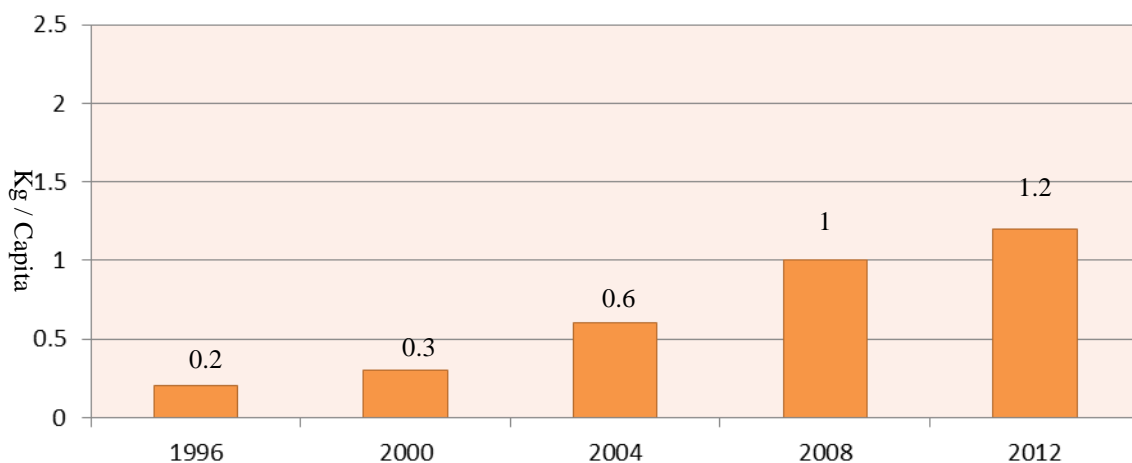

Figure 5-1 Composites consumption and production per capita growth in Iran

Iran ranks 10<sup>th</sup> in the world and 4<sup>th</sup> in Asia for research and publication in the area of composites technologies, while there are over 200 companies currently producing composites in Iran.

Table 5-1 Composites technology status in Iran

Article publications (rank in the world)	10 <sup>th</sup>
Article publications (rank in Asia)	4 <sup>th</sup>
Composites consumption per capita	1.2 kg
Number of active companies	More than 200
Number of universities & research centers	15

### 5.3 Iran Composites Institute (ICI)

Considering the importance of composite materials and technologies in the 21<sup>st</sup> century, Iran Composites Institute (ICI) was founded in 1999, jointly by the Center for Innovation and Technology Cooperation (CITC) and Iran University of Science and Technology (IUST). ICI is responsible for the development of composites technologies in the country. The goals of the Institute include; scientific research on composites, improving relationship with industries, development of composites technologies in the country, and convening scientific conferences on composite materials.

This institute consists of three departments, namely: mechanical engineering, materials engineering, and nanotechnology. Different subjects such as various resins and fibers, manufacturing and production methods, and design of composite structures are being investigated in the institute.

## 5.4 Major Composites Achievements & Products

### Resins

Iran produces several types of resins, which are among the main components of polymer matrix composites (unsaturated polyester resin & vinyl ester resin, phenolic resin and gel coats).



### Glass Fibers

Glass fibers are the main reinforcing fibers in polymer matrix composites (PMCs) which are used for the production of Glass fiber Reinforced Plastic (GRP) pipes, car components, composite boats, and pultruded profiles amongst others. Iran Composites Institute has developed a technology for production of glass fibers and is working on its commercialization.



### Fajr-3 Full Composite Aircraft

Fajr-3 Full Composite Aircraft is a 4-seater sport aircraft with a full composite body. This aircraft received:

Design organization approval (DOA) under JAR-21

Type certificate according to JAR-23



### Composites Folded Structures

The composite folded structure is a frameless and earthquake resistant structure with further advantages of light foundation and fast installation.

### Reinforcement of Gas and Oil Tanks & Pipes

Composites are also used for reinforcement of gas and oil tanks & pipes, with the following advantages:

- Longer service life;
- Prevention from leakage and fracture;
- Protection against corrosion;
- Repairing during operation.

- Reinforcement of Gas and Oil Tanks & Pipes



Before Reinforcement



After Reinforcement

# 6. Information and Communication Technology

## 6.1 Introduction

As a developing and capable country, Iran has an active and timely participation in the international arena. A lot of public/private organizations as well as training and academic institutes are directly and indirectly involved in Information and Communication Technology (ICT) related activities.

In recent years, Iran has focused on Information Technology which covers various fields from instalment of applications to designing complex computer networks and information data centres as well as developing e-commerce, e-banking, e-citizenship, e-city, e-government, and e- services. Iran's development in e-cities is inevitable, considering the population growth and changes in the structure of interpersonal relationships.

**“The Iranian ICT market is estimated to be worth US\$1.5 billion annually, which has remained largely unexploited by foreign companies”.**

ICT sub-industries include electronics and hardware, networks, and software with a range of different products. Iran’s most important resource in the ICT sector was its educated and talented workforce. Estimates showed that the country had more than 70,000 university graduates in the ICT field, which encouraged the government to plan a program to train 300,000 youths for jobs in this sector.

**“All factors considered, Iran is a good choice for investment and outsourcing in ICT related fields.”**

## 6.2 Current ICT Status in Iran

The Islamic Republic of Iran is among the first countries that have had a growth rate of over 20% and the highest level of development in telecommunications. By the end of 2009, Iran's telecom market was the fourth largest market in the region at 9.2 billion dollars and is expected to grow to 12.9 billion by 2014 at a CAGR of 6.9 percent.

Telecommunication Company of Iran (TCI), established in 1971, is the main responsible administration for the entire telecommunication affairs. TCI is the fixed-line incumbent operator in Iran offering services in fixed telephony, DSL, and Data services for both residential and business

customers throughout the country.

Major mobile operators in Iran include the Mobile Company of Iran (MCI) with about 70% market share, MTN Irancell (28%), and Talia (1%), as demonstrated in figure 6-1.

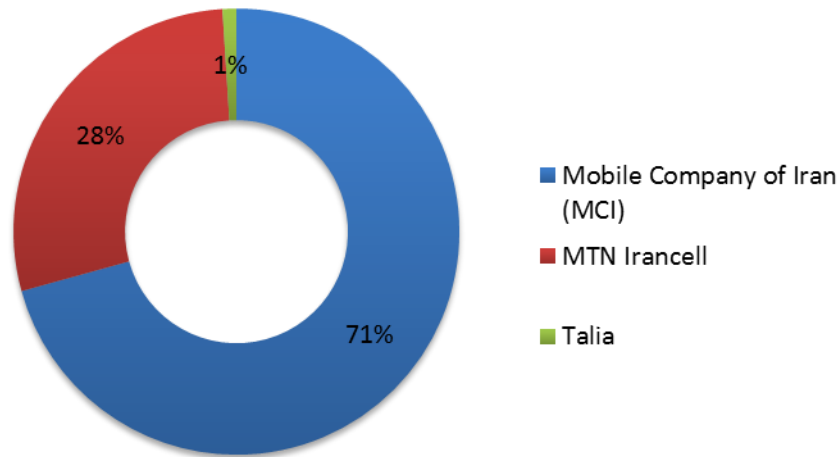

Figure 6-1 Iranian major mobile operators market share

Mobile subscribers' statistics by operator are as follows:

- TCI: 44 million sold SIM cards, 34 million active SIM cards (by type: 16.5 million post-paid and 28 million pre-paid SIM cards)
- MTN Irancell: 18 million SIM cards.
- Rightel: more than 500,000 subscribers.

The two national operators, MCI and MTN Irancell, both offer GPRS-based data services. In 2012, the 3rd Mobile Operator (Rightel) launched its network which contains 3G services.

Table 6-1 shows the number of fixed line and mobile telephone users in Iran, and the country's rank in the world corresponding to each of these items.

Table 6-1 Some Iranian telecommunication statistics (2012) <sup>1</sup>

Item	No.
Telephones - main lines in use	28,758,465
Telephones - mobile cellular subscription (per 100 people)	76.92

<sup>1</sup> World Bank statistics: <http://search.worldbank.org/data?qterm=mobile&language=EN&format=>

Regarding the number of Internet users, according to the statistics, in 2010 Iran constituted a great proportion of the total internet users in the Middle East region, with 24 million users. In 2012, the number of internet users in Iran grew to 42 million users, keeping the country in the first rank in the Middle East region in this regard (figure 6-2).

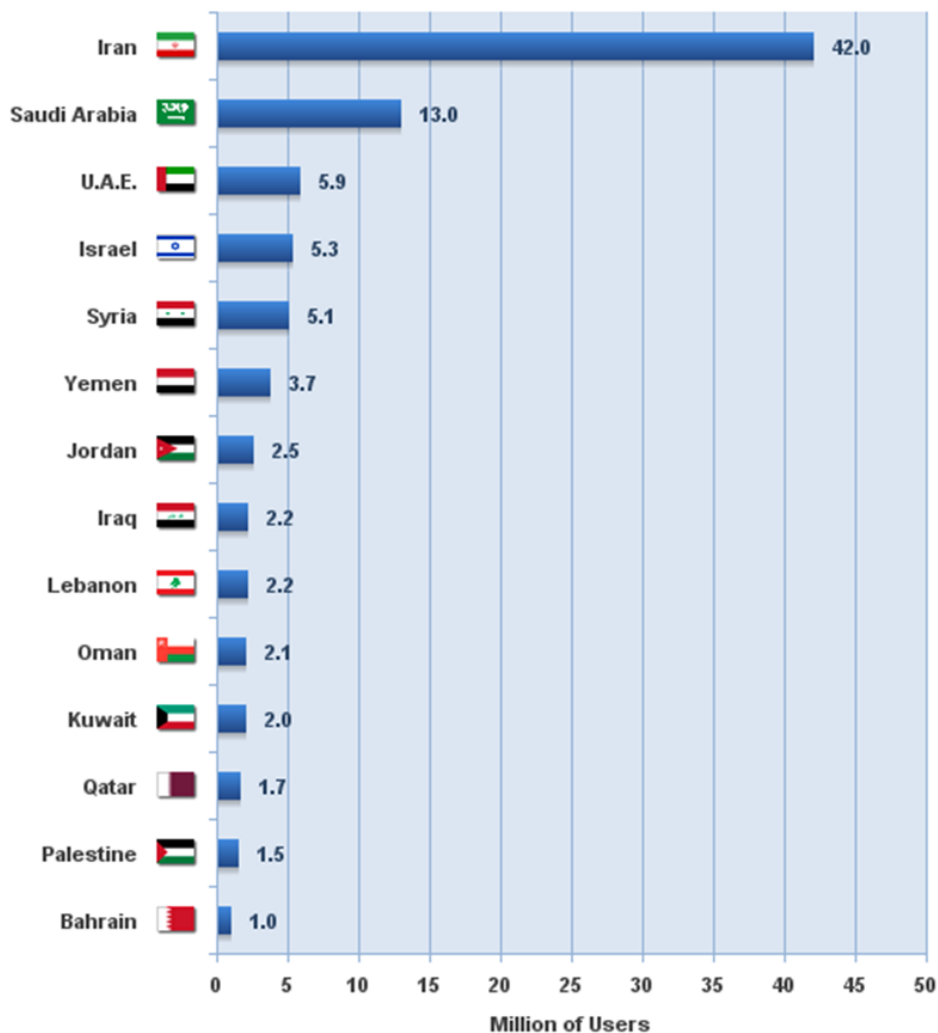

Source: Internet World Stats - [www.internetworldstats.com/stats5.htm](http://www.internetworldstats.com/stats5.htm)

Figure 6-2 Middle East internet users, June 30, 2012



Table 6-2 shows the growth in number of Iranian internet users in the period 2000-2012.

Table 6-2 Internet Growth and Population Statistics

Year	Users	Population	%Population (Penetration)	Usage Source
2000	250,000	69,442,905	3.8%	ITU
2002	5,500,000	69,442,905	7.5%	ITU
2005	7,500,000	69,442,905	10.8%	ITU
2008	23,000,000	71,965,223	34.9%	ITU
2009	32,200,000	72,969,284	48.5%	IWS
2010	33,200,000	76,923,300	43.2%	IWS
2012	42,000,000	78,868,711	53.3 %	IWS

Source: <http://www.internetworldstats.com/me/ir.htm>

As of 2010, international connection services were provided exclusively by Infrastructure Companies of Iran. Submarine fiber-optic cable to UAE with access to fiber-optic line runs from the state of Azerbaijan through the northern portion of Iran to Turkmenistan with a further expansion to Georgia and Republic of Azerbaijan. There is also an Iran-Kuwait submarine communications cable in the Persian Gulf. The next program is to connect the country with global optical fiber networks from northern and north-western boundaries.

According to the IT industry competitiveness index (2007), Iran ranked 8th in the Middle East & Africa in this field. [Economist Intelligence Unit, 2007].

### 6.3 Ministry of Information and Communication Technology

The ministry of Information and Communication Technology is responsible for planning, support, and development of the national information and communication infrastructures and capabilities of the country.

Other governmental institutions relating to ICT include: Supreme Council of Cyber Space, Ministry of Science Research and Technology, High Council of Informatics, and Ministry of Commerce.

### 6.4 Iranian ICT Infrastructures

Communication services started in Iran in 1889, and since then the country's telecommunication networks have kept pace with innovations in the industry. Apart from the incumbent Telecommunication Company of Iran (TCI), there are 28 provincial telecommunication operators

in the country. According to the ICT Infrastructure index in 2010, Iran was ranked 4<sup>th</sup> amongst developing countries in business, consumer, and government economic sectors, followed by Malaysia, Russia, and Turkey (Table 6-3).

Table 6-3 Indexes for ICT Infrastructure for selected countries, by economic sector, 2010

ICT infrastructure index				
	Country	Business	Consumer	Government
Developed countries	United States	85	57	79
	Australia	80	53	77
	Canada	79	48	79
	France	60	46	73
	Germany	59	49	72
	Japan	63	77	75
	South Korea	57	96	88
	Sweden	85	72	87
	United Kingdom	74	50	71
Developing Countries	Brazil	50	64	85
	China	23	69	48
	India	6	24	39
	Iran	17	53	32
	Malaysia	60	77	78
	Russia	52	93	51
	Turkey	59	77	80
	South Africa	56	52	74

### 6.5 Sub-Industries of ICT

In this section, ICT sub-industries are briefly introduced.

#### Electronics and hardware

The electronics and hardware industry in Iran includes different fields such as electronic appliances, microelectronics, computer hardware, telecommunications devices, and smart cards. Iranian manufacturers are active in all of these sectors. The main exporters to Iran are South Korea, Germany, France, and Japan; with European companies mostly involved in telecommunication devices. Much of the components used in the industry are produced domestically, except drives and chips.

**“About one million PCs are sold in Iran annually; a market that is worth approximately US\$700 million and is growing at an annual rate of over 30 percent.”**

The electronics and hardware industry generates 0.5 percent of the country’s GDP. It has grown steadily over the past ten years and is expected to grow faster in the future with the support and enabling policies of the government.

## **Networks**

Iran’s networking structure consists of LANs, VANs, and VPNs. Ethernet LANs are popular and structured cabling is used extensively. About 100 Iranian companies provide network-related services including network equipment importing and manufacturing, network design and installation, and cabling.

**“The market value of this sector is approximately US\$70 million per year, with 25 percent annual growth.”**

## **Software**

The software industry consists of areas such as providing financial solutions, manufacturing information systems, office automation, graphic and design solutions, engineering and scientific applications, and e-learning solutions. The government has included this industry among its 6 new defined industrial priorities. Measures that have been adopted to boost the industry include supporting domestic production, providing financial feedback for software companies, and awarding government outsourcing contracts to Iranian companies. There are more than 500 registered software companies – and many more unregistered groups – in the country.

**“Eight of them have received ISO9001 and TickIT certifications, with others planning and working towards certification.”**

## 6.6 Major Iranian ICT Products

### Analog TV Transmitters

#### Application

MI Analog TV Transmitters with different output powers are renowned for their high degree of reliability backed by several years of flawless performance in different and adverse environmental conditions. Currently about 60% of all stations of the National Broadcasting of Iran (IRIB) in low and medium powers are equipped by MI Analog TV Transmitters.

#### Features

- LDMOS technology
- IF SAW filter
- High power and high temperature protection
- Overvoltage and overcurrent protection
- VSWR protection
- 10W to 10KW
- 1+N configurations
- UHF/VHF full band

### DVB-T/H Transmitters

#### Application

MI DVB-T/Transmitters have been designed and tested in different fields and under different environmental conditions. The transmitters are designed to meet all requirements of demanding clients with different power outputs. The transmitters are very user friendly with reliable remote monitoring and control systems. Adoptive digital pre-corrector of the transmitters have notably increased their power efficiency and guaranteed their extremely high RF performance.

## Features

- LDMOS technology
- Adaptive digital linear and non-linear protection
- All DVB-T and DVB-H modes supported
- Hierarchical and non-hierarchical modes supported
- Multi-platform remote control
- SFN and MFN synchronization supported
- VSWR protection
- High power and temperature protection
- Over voltage and current protection
- 1+N configurations

## Channel TV Transmitters (Satellite Translators)

### Application

Terrestrial TV and FM coverage to small towns and villages especially those located in remote areas has always been a difficult task. In order to solve such problems, MI has designed a contact solution consisting of 4X 10W Analog TV Transmitters and 4X Satellite receivers, all mounted in a single 30U rack together with the necessary combiner. By this simple solution, 4 TV channels received via Satellite receivers can be propagated in the target areas. A 6-Channel TV Transmitter (Satellites Translator) is also available.

## FM Transmitters

### Applications

MI FM Transmitters are designed to have excellent specification. High power is guaranteed by an amplifier module with 6th generation LDMOS transistors. The air cooling system added to a very good heat sink keeps the amplifier temperature very efficient. A microprocessor monitors and controls the current of the transistor and voltage of the power supply. Output power, reflected power, and temperature of the heat sink are also monitored. MI FM transmitter features can be remotely set by a USB, serial communication, Ethernet ports, and SNMP protocol.

## Features

- Air cooling
- Very high efficiency
- Manual and automatic mode to reach desired power
- Multi-platform remote control
- USB controllable
- VSWR Protection
- Over Voltage and Current Protection
- High Power and Temperature Protection
- Dual Exciter or 1+N Configuration

## Combiners and Filters

### Applications

Bandpass filters are required at the output of transmitters to suppress out-of-band emissions created due to the amplifiers non linearity. Combiners are usually used to transmit various channels on a single antenna by combining Inputs with different frequencies into one output. MI has different designs depending on applications (DVB-T/H or analogue) and different powers.

## Features

- analogue TV, DVB-T/T critical and non-critical masks
- Low insertion loss
- Good temperature stability
- Compact design
- Output monitoring sampler
- One guard channel (Combiners only)
- High isolation between inputs (Combiners only)

## Satellite Equipment (ALGO-NMS-SAT-SCPC)

### Automatic Fixed Satellite Antenna ALGO-AN-AFSAT-AD

ALGO-AN-AFSAT-AD is a full automatic fixed antenna which will be installed on the existing foundation supplied by satellite operators. This antenna is controlled by the HUB center and does not need an operator to adjust it after initial installation. The connection between controller and HUB center will be established by NMS (Network Management Software) installation, in this case

operators can provide the modification with 3 directions (Az., El., Pl.) along with other parameters. Low maintenance is yet another advantage of this antenna. Operators can also control the parameters and quickly adjust the direction from the central station.

### **Applications**

- Automatic GEO satellite finding
- Antenna positioning and fine tuning
- Sending and receiving data
- Two ways GEO satellite finding
- Monitoring satellite system
- Tracking inclined GEO satellite

### **Features**

- Covers all GEO satellites
- Customized to work with all satellite modems (EMS, Sat path, Comtech, Newtec, iDirect)
- D freedom (Azimuth, Elevation, Polarization)
- Remote controlled by network system
- One time installation
- Automatic satellite finding with Network Management Software
- Can be supported by 180cm fiber glass dish
- Working ability with  $\pm 2^\circ$  tolerance
- Tunes to the prior position when unable to find satellite

### **Satellite Network Management System-SCPC DAMA**

#### **Applications**

- Satellite Network Management
- Management for satellite Mini-Hub
- Bandwidth Management
- Monitoring and Control Stations

## Features

- Real-Time and IP Based
- Element Manager and Bandwidth Manager
- Monitoring, Control and Configuration
- Capability of Integration with other Network Management Systems

## Dictation Systems

### • Nevisa Persian Voice Dictation System

Nevisa dictation system is a large-vocabulary speech dictation system based on the ASR Gooyesh Pardaz continuous speech recognition engine. Persian (Farsi) speech is recognized instantly without dependence on speakers. Thus, time and costs will be saved significantly in writing Persian documents. The flexibility of Nevisa in adverse environmental conditions is achieved by advanced noise robustness techniques. The background adaptation makes the recognition more accurate as time goes by. By now the accuracy of the Nevisa dictation system is more than 95%.

## Features

Some key features of Nevisa, the first robust, accurate, and fast speech dictation software in Persian are as follows:

- Excellent accuracy (more than 95%)
- Real time recognition
- Continuous Speech Recognition
- User-friendly GUI in Persian and English
- Dictates directly into any Windows-based editor (like M.S. Word, Notepad...)
- Add, change, and customize vocabularies
- Choosing between accuracy and response time
- Incorporates state of the art linguistic knowledge
- Speaker and environment adaptation
- Creates user-specific profiles



- **Health-care Specific Dictation**

Medical dictation is another solution offered by the ASR Gooyesh Pardaz company which is exclusively made for doctors. Being supported by a professional medical dictionary, this product allows doctors to complete the required forms, fulfil patient's personal requirements and health status as well as dictate and record each patient's prescription.

This product offers doctors the ability to perform all of these tasks and even more by just talking. They can name the patient, see his/her complete file and make a record of the treatments that have been prescribed. This system does not require any special knowledge of computers and can save time which could be spent saving lives.

### **Access Control**

An access control is a security system which determines who, where, and when a person is allowed to enter or exit. Historically this was partially accomplished through keys and locks, but mechanical locks and keys do not provide records of the key used on any specific door and the keys can be easily copied or transferred to an unauthorized person.

Electronic access control uses computers to solve the limitations of mechanical locks and keys.

An access control point is typically a door but can also be a turnstile, parking gate, elevator, or other physical barrier where granting access can be electrically controlled.

### **Mobile Repeater**

Consultancy and Solution Providing Services

The main categories in mobile reception problems are indoor and outdoor problems.

#### 1) Outdoor

The main outdoor problem is weakness of the signal; in this case the customer is usually interested in expanding the mobile coverage to bigger areas. The main customers are mobile operators that prefer to use repeaters instead of installing new BTS. Another difficulty is traffic problem; in this case the operators are interested in transferring the existing traffic to another cell.

The best and most economical solution for these cases is use of high power professional outdoor repeaters with NMS monitoring and control systems. There are different types of outdoor repeaters (Band-Selective, Channel-Selective, and Frequency-Shift) and depending on the case, the best one will be offered as a solution to the problem.

Analysis of results from the site survey and test results from the TEMS system can determine the best location for the repeater site, type of tower and its height, type of repeater, required accessories such as type of donor/service antennas and their locations on the tower and finally the FSR of the site.

## 2) Indoor

There are many indoor mobile reception problems such as weakness of the signal, ping-pong effect, interference, low traffic, etc..

To solve the above problems there are several solutions: Using Micro BTS, Using Indoor repeaters, and a Combination of using micro BTS and repeaters. Depending on the nature of the problem and the indoor area that has to be covered, the solution will be different. This group has offered solutions in more than 300 projects that have been carried out in the past 6 years. The best but most expensive solution is Using Micro BTS and has to be performed under supervision of operators in locations with high traffic.

## **Behin AFIS (Automated Fingerprint Identification System)**

Behin Pajouhesh Company researches and develops both software and hardware biometric productions. Carrying out extensive research and exploiting local experts, the company has achieved the ability to collect and search on large scale biometrical databases that include millions of fingerprints.

## Features

- Physical Access: Secure areas, Transportation lots
- Logical Access: Network (LAN, WAN, Secure transactions) Confidential Files: Payroll, Trade secrets
- Government Application: Border Crossing, Driver License, Voter Registration, Healthcare, and Other Services
- Law Enforcement: User Authentication/Verification, Criminal Records, Immigration Status Tracking, ID in Time of Death

This system captures flat and rolled fingerprints electronically and converts them to features after the extraction process. It then uses these features to determine the similarity between fingerprints in the matching stage. Because it makes use of the latest advances in image processing algorithms and artificial intelligence, both the capturing technology and used matching algorithms are very accurate and hi-speed.

## Benefits of Using Biometric Technology

- Accuracy/Security
- Convenience
- Cost effective/Savings

# 7. Aerospace

## 7.1 Introduction

Aerospace is a very diverse field, with a multitude of commercial, industrial, and military applications. The term is used to refer to the industry that researches, designs, manufactures, operates, and maintains vehicles moving through air and space. Iranian aerospace industry today is on the threshold of a new era of development with many successful projects in both civil and military applications. The industry is poised for exponential growth in the coming years by expanding its existing capacities. In this chapter, after introducing some Iranian space centers, some major Iranian aerospace achievements are presented.

## 7.2 Alborz Space Center

Alborz Space Center with an area of 42 hectares in the west of Tehran began its activity in 1972. The following is a brief review of the center's activities as well as the changes and developments made in this center over the past 34 years.

Iran started its space science activities when US National Aeronautics and Space Administration (NASA) launched the first remote sensing satellite, Earth Resources Technology Satellite (ERTD-1), later renamed Landsat, in 1972. At that time, Iran tried to keep up with the developments made in this technology. In this regard, being supported by the United States of America, Iran decided to obtain the satellite data directly. Iran's request was agreed by U.S.A. and it was approved for the Iranian receiver station to provide services to 33 countries covered by the receiving antenna; besides, these countries were not authorized to build such stations in their own land. Thus, a contract concerning temporary purchase, installation, set up, and operation of satellite data receiving station was made between Iran and U.S. General Electric Company in 1974.

With support of the management of the Radio and Television Organization and upon completion of construction, contractors began the installation process in 1976 and the first phase including tracking and receiving information became ready for operation within 2 years. Concurrent with the Islamic Revolution in 1978, this station had already obtained 3 complete sets of Landsat information and delivered them to the archive.

As per the contract and based on the pattern of different satellite data stations installed in America, Canada and some other countries, it was decided to install 5 different phases in this station. However, the American contractor left Iran due to the crisis in the country following the Islamic Revolution and management of this project was assigned to Iranian experts.

By approving the 4th development plan and forecasting space infrastructure development, Mahdasht Space Center once more came to attention and the necessary measures were taken to reinforce TRF building (receiving and tracking information from satellites), and to reconstruct and change its usage. Moreover, developing Mahdasht Space Center and changing its usage with emphasis on establishment of TT7C satellite stations, remote sensing basic laboratory and regional space research and training center were on the agenda. In the next stage, active receiving stations of the Tehran center were transferred to Mahdasht Space Center and once more satellite images were received in this center. At present, active receiving stations in this center include TERRA/MODIS, NOAA/HRPT, and FY2C. Satellite images are being received every day and night and along with produced metadata archived in the spatial portal system of the organization after being processed.



### 7.3 Some Iranian Achievements in Aerospace

#### Sina-1 satellite

Sina-1 satellite is the first Iranian artificial satellite and space explorer launched at 6:52 UTC on Oct. 28, 2005 on board a Cosmos-3M Russian launch vehicle and successfully put into exclusive orbit of the Islamic Republic of Iran. It was launched from the Plesetsk Cosmodrome in Russia. Sina-1, weighing 170 kg, was designed and built by Omsk-based Russian company Polyot at the request of the Ministry of Science, Research and Technology. With the launch of this satellite, Iran became a member of the world space club.



The NASA registered code for Sina-1 is D043-2005 (this code is dedicated to those satellites which have been launched successfully) and its Catalog Number or USSPACECOM object number is 28893.

### **Safir-e-Omid Satellite Launch Vehicle**

Safir-1 satellite launch vehicle is the first satellite carrier rocket built by the Aerospace Industry of the Islamic Republic of Iran.

By building this launcher, Iran has become the 9th country that currently has a proven orbital launch capability. This launch vehicle is composed of more than 10000 different pieces in its components including engine, body, navigation, and control systems, all of which have been localized by experts in various university fields within 10 years.

Safir satellite launch vehicle was made in 2 generations known as 1-A and 1-B. 1-B launcher is the completed generation of this launcher and its engine thrust is increased

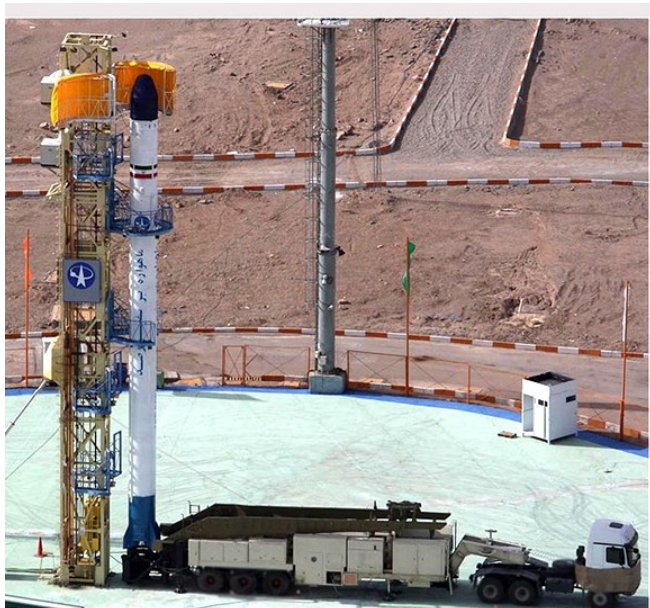

from 32 to 37 (a 50% increase in weight and 25% in altitude) and is capable of carrying a satellite up to 50 kg in elliptical orbit of 300-450 km.

### **Omid Satellite**

It is the first indigenously launched satellite with all of its components designed and produced in Iran. Omid satellite was launched into orbit on February, 3, 2009 coinciding with the Thirtieth anniversary of the Islamic Revolution and its 82-day mission was accomplished when colliding with thick atmosphere of the western regions of South America and the Pacific Ocean on Apr. 25, 2009.

Omid was Iran's second satellite, after Sina 1, in orbit. NASA's registered code for Omid satellite is A004-2009. Its Satellite Catalog Number or USSPACECOM object number is 33506. This 27 kg satellite is a telecommunication satellite which transforms information in frequency band of UHF.

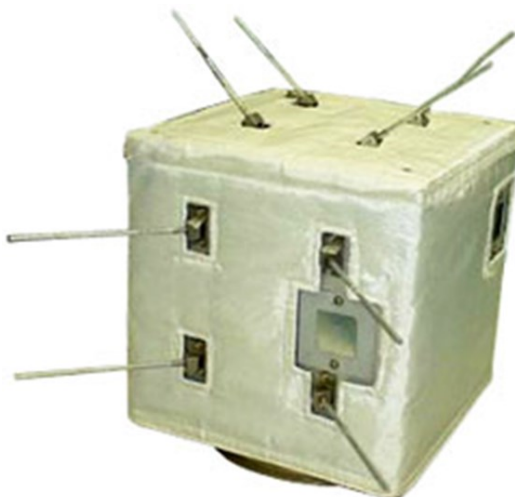

Omid satellite was a light-weight satellite which was placed into orbit by Safir-2 launch vehicle. The satellite with a lifespan of 50 days had missions related to communication between the satellite and ground station, determining orbital specification, and remote sensing of subsystem specification.

This satellite entered the atmosphere over 246-377 km altitude from earth. According to the defined mission for Omid satellite, it lost its energy in the lower orbit due to gravity and crashed to earth after a while. The launch of Omid makes Iran the 9th country to develop an indigenous satellite launch capability.

### **Rasad Satellite**

Rasad satellite is Iran's second satellite launched aboard a Safir-B carrier rocket into space and is also Iran's first imaging satellite. Rasad, fully named as Rasad-1, was launched into space on June 15, 2011, from a launch site in Semnan province, then entered the atmosphere again on July 6, 2011 and accomplished its 3-week lifespan. It had a mass of 15.3 kg and was placed into an orbit of 55.7 degrees and altitude of 246-288 km from earth. It was equipped with solar panels to generate power and returned images with a resolution of 150m. NASA's registered code for Rasad satellite is A025-2011.

### **Navid Satellite**

Science and Industry satellite called Navid in brief is Iran's third indigenous satellite and the first satellite built by satellite research center of Elm-o-Sanat University (Iranian University of Science and Industry). It was launched in celebration of Iran's Space Technology Day on Feb. 03, 2010. The mission of



Navid satellite was imaging the earth's surface with a 750-m resolution based on scanning method and in single-band mode. This satellite was launched into space from Semnan space base at 3:30 AM (in local time) Friday, Feb. 03, 2012.

NASA's registered code for this satellite is A005-2012. Navid satellite was cubic-shaped and its dimensions were 50\*50\*50 cm with a mass of 50 kg. It was designed to be placed into elliptical orbit at an altitude of 250-375 km with an orbital inclination of 55 degrees. The satellite communicated with the ground station through three senders and receivers in VHF and UHF

bands. Its energy was supplied by solar panels installed on the subsidiary body of the satellite structure as well as a battery. In addition, regulators and energy convertors were used in order to supply its energy. Given the orbit of this satellite, it is expected to orbit Earth every 90 minutes.

### **Pishgam**

Iran's 5th research explorer, Pishgam explorer or explorer 5, sent a three year old male rhesus monkey on a 16-minute travel from Semnan space base to a sub-orbital mission at 12:37 AM, Jan. 28,

2013. After completing the predicted steps and achieving the respective speed and acceleration, and altitude of 120 km from the Earth, Pishgam explorer came back to earth and the living species traveling with the explorer was recovered successfully upon return. The monkey's heart rate at the moment of acceleration was 140 beats per minute. In a press conference, the head of the Space Research institute for Astronautically Systems called the first monkey astronaut "Pishgam" which means "pioneer". The cargo landed 80 km away from the launch site.

At the beginning of the operation, it took 30 seconds until the explorer's speed passed Mach 1. Along the return direction, a maximum speed of Mach 5.5 was achieved. Again, speed passed Mach 1 and reached a maximum speed of Mach 4.5 along the return direction. Due to fins at the end of the cargo that prevented the bio-capsule to be reversed and cargo floor which had a special geometric shape, the explorer's speed decreased such that it reached Mach 0.8 and because of umbrellas, speed of this explorer reached 8 m/s (288 km/h) at the landing moment.

Bio-capsule of Pishgam Explorer carrying a rhesus monkey contained all the necessary life support systems. This 60 kg explorer was able to carry a rhesus monkey weighting 4-5.2 kg and provide the appropriate conditions for his survival and monitoring during a suborbital flight for 20 minutes. In this capsule, a special kind of energy absorbent was embedded in the passenger compartment which

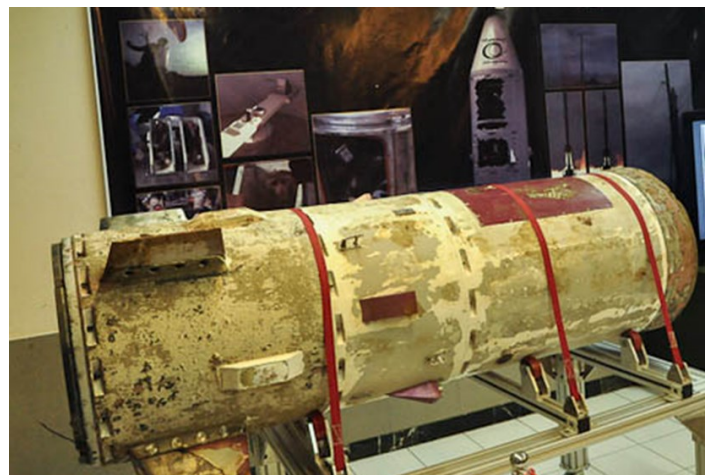





could absorb more than 90% of the vibrational and unfavourable energy so that the passenger could feel more comfortable during the mission. Using chemical technology, this bio-capsule was equipped with a system for decreasing CO<sub>2</sub> and producing oxygen which was able to maintain the critical atmospheric gasses of the capsule at a favourable level within a continuous period of 5 hours. In order to control the internal temperature of the capsule, a passive thermal control system was used which could act in the cold winter and hot summer and even in extremely cold conditions in outer space to maintain the ideal temperature inside the capsule. Internal pressure of the capsule was supplied by specific methods for sealing the capsule.

# 8. Water and Wastewater Technologies

## 8.1 Introduction

Iran has a hot, dry climate and limited water resources. In addition, Iran's population is growing significantly with a growth rate of 1.4%. Although water supply and sanitation in Iran have witnessed important improvements, especially in terms of increased access to urban water supply, significant challenges still remain, particularly concerning sanitation and service provision in rural areas. Since the 1980s, access to urban water supply has increased from 75.5% to 98%. Nevertheless, water demand is growing, especially for irrigation and industries.

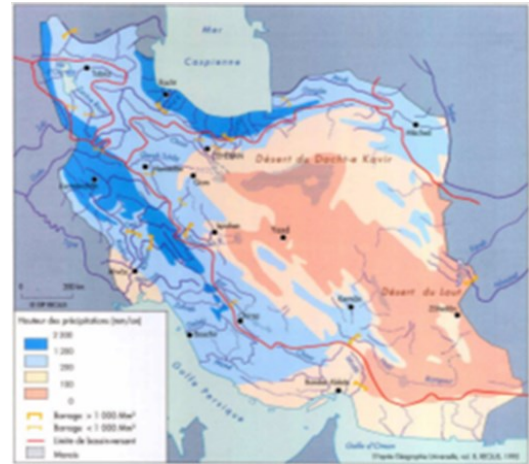

Rivers and water resources in Iran

## 8.2 Current Water Resources in Iran

- Average rainfall volume: 376 km<sup>3</sup>/year
- Evaporation before reaching the rivers: 66 %
- Total renewable water resources: 137.5 km<sup>3</sup>
- Total surface runoff: 97.3 km<sup>3</sup>/year
- Catchment areas: 6 main and 31 secondary catchment areas, as follows:
  - ⇒ The Central Plateau in the center (Markazi)
  - ⇒ The Lake Orumiyyh basin in the northwest
  - ⇒ The Persian Gulf and Gulf of Oman basin in the west and south
  - ⇒ The Lake Hamoon basin in the East (Mashkil Hirmand)
  - ⇒ The Kara-Kum basin in the Northeast (Sarakhs)
  - ⇒ The Caspian Sea basin in the North (Khazar)
- Total surface water and ground water withdrawal: 68 percent of the total actual renewable water resources.
- Agricultural, municipal, and industrial water consumption: 80, 5.4, and 1.1 km<sup>3</sup> respectively.
- Qanat: traditional canal system in Iran for using groundwater, it is a subterranean water collection and conduction system for transporting water from one place to another.

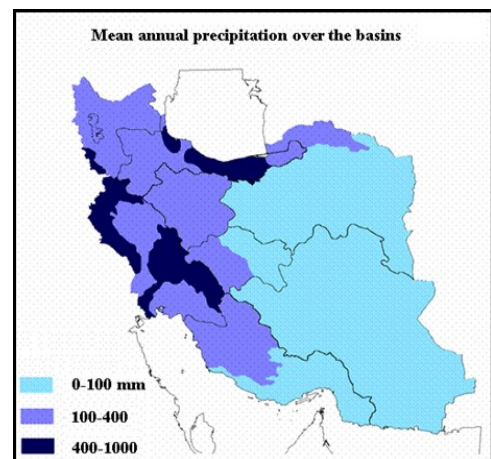

Mean annual precipitation over the basins

### 8.3 Major Iranian Water Industry Achievements & Technologies

#### Desalination Technology:

Demand for desalinated water in Iran is increasing. Many Desalination Plants have already been constructed with plans to construct many more in the future. MED, MSF, RO, and NF technologies are developed for desalting water supplies.

#### Ground Penetration Radar (GPR)

##### Technology:

- GPR technology uses electromagnetic (radio) wave to image the subsurface.
- Electromagnetic waves (10-2000 MHz) are transmitted into the earth and the reflected signals are recorded.
- The differences of “electrical conductivity” and “radio wave propagation velocity” in surface materials generate reflections.
- At each station, a time trace is recorded, which shows the amplitude of reflected signals.

##### GPR Advantages

- Completely non-destructive
- Very simple and fast data acquisition
- Cost effective
- Very high resolution

##### GPR Applications

- Leakage detecting of water transport facilities.
- Urban life-lines mapping (pipes, cable).
- Environmental studies (pollution studies).
- Geological studies (structural and stratigraphic).
- Engineering geological studies (soil mapping, cavity mapping).
- UXO detection (mines, explosives).



Desalinated Water Demand

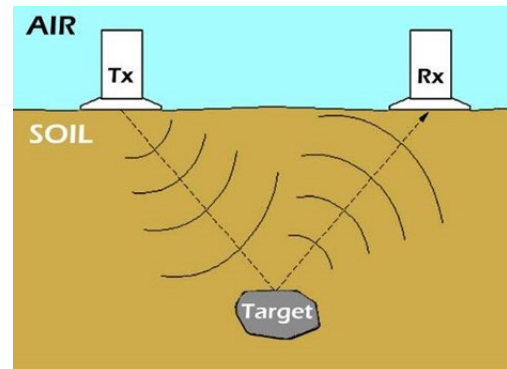

Leak detection with GPR technologies



Investigating with GPR

- Construction tests (concrete reinforcement, foundation quality).
- Archeology (graves, tombs).

### Disinfection Technology (Chlor-Ozone)

The Chlor-Ozone water purification device is a compact and safe device for generation of electrochemically activated oxidants that contain Chlorine (95%), Chlorine Dioxide (3%), and Ozone (2%).

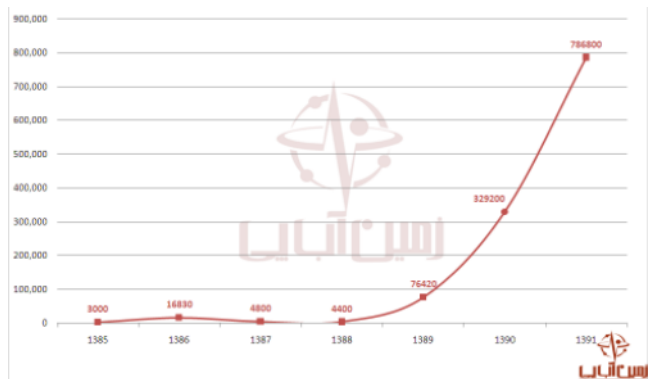

Figure 8-1 GPR Investigation growth in Iran (meter)

### Applications

- Drinking water purification of any output capacity;
- Water disinfection and purification in swimming pools, bath-houses, and saunas;
- Disinfection of stock buildings and other agricultural facilities;
- Disinfection of residential, industrial, and agricultural waste water;
- Disinfection of medical waste products before their reclamation;
- Water disinfection in reverse cooling water -supply systems installed at power-generation complex enterprises, and at chemical and metallurgy industry enterprises;
- Water disinfection in closed systems of technological water circulation applied at industrial enterprises, including food industry enterprises.

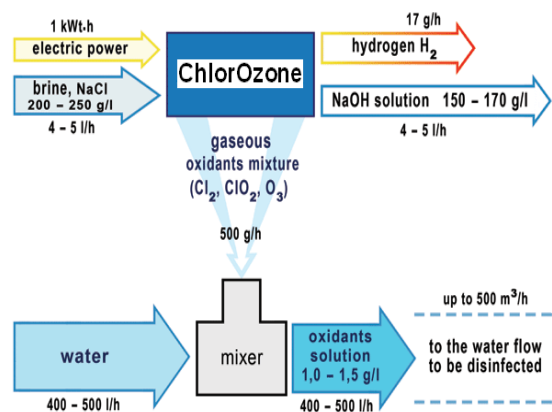

Figure 8-2 Chlor-Ozone technology

### Advantages

- influence on the whole spectrum of pathogenic microorganisms, including spores
- advanced disinfection ability
- no chlorination by-products generated
- no resistant microorganisms strains originated



A Chlor-Ozone Plant in Iran

- No toxicity, thanks to active substances – amicable to organisms of human beings and of warm-blooded animals
- Ecological compatibility and no accumulation in surrounding environment
- Harmlessness for human beings and surrounding environment
- High economy efficiency and rapid pay-back capability
- Compactness and other advantages

### Portable water treatment system for turbidity reduction

Portable water treatment system with turbidity removal technology is a new and cost effective product compared with similar technologies.

Portable Water Treatment Plant is installed inside a 6 meter transport container for easy manoeuvrability so it can be moved quickly to any location.



### Advantages

- Very suitable and economical for emergency water treatment
- Applicable to the treatment of both surface water and groundwater
- No need for replacement of filters
- No limitation for microbiological contaminant or high TDS
- Mobility in all conditions
- No requirement for separate pre-treatment (if the TDS and salinity are at standard levels)

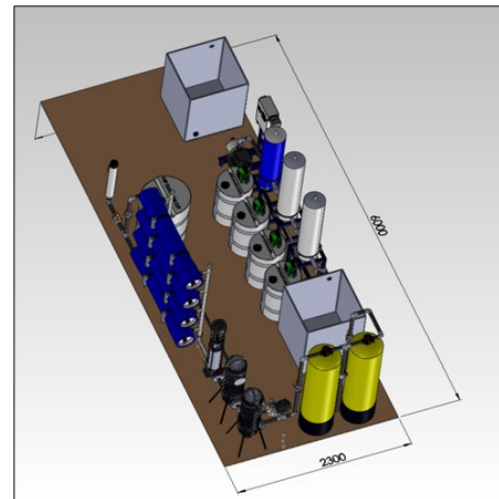

Capable of continuous operation without interruption

Includes all treatment units such as pre-treatment, treatment, disinfection, and water packing system

# 9. Marine Industries

## 9.1 Introduction

There are enormous potentials and markets available for marine industries in Iran. Two of the three most important transport corridors in the world pass through Iran, which indicates the importance of the maritime transport in the country.

Maritime industries include shipbuilding companies, equipment and raw materials, maritime transport and transit, fisheries, etc. The overall supply chains for marine industries play a crucial role in the economy of the country.

Some of the notable achievements are an experienced labour force, good facilities and equipment, and efficient management of offshore projects. These include offering services to passing ships in the region, fuel injection as well as manufacturing, fixing, and maintenance of offshore drilling rigs.

## 9.2 Current Status of Marine Industries in Iran

With its beaches stretched in the North and South of the country (about 2900 km), the extensive exchange of commercial and petrochemical goods, and petroleum and construction of offshore platforms in oil fields, Iran is highly dependent on marine industries for its extensive domestic needs.

Iranian marine industries include all sea-related industries and services, the most important of which are maritime transport, ports and port related services, ship building and maintenance industries, maritime platforms and structures, construction and repair, military marine industries, fisheries, and marine tourism.



### 9.3 Major Iranian Achievements in Different Fields of Marine Industries

#### Shipbuilding

Due to importance of shipbuilding, offshore constructions, and maintenance, a variety of activities have been undertaken in Iran. During past years, in addition to the ability of designing and constructing oceangoing vessels, valuable experiences have been acquired in building and repairing fishing ships, tugs, landing crafts, barges, as well as hospital and service ships in small and medium sizes.

Construction of oceangoing vessels in ISOICO shipbuilding complex with the following specifications is only one example of many works carried out in this area: 187m length, 30m width, 16.5m height, and capacity of transporting 2'200 containers.

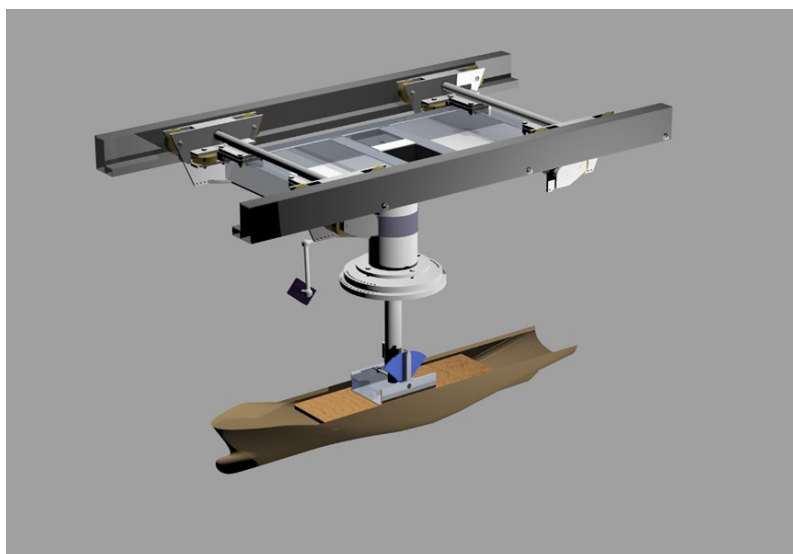



Construction of Aframax ships-oil tankers- to mention one among many, is another example of the shipbuilding activities in Iran. These ships with 250m length, 44m width, and 113,000 ton capacity, a draft of 8.14m, and speed of 16 knots, are under construction upon the order of Venezuela Oil Company. They are built for the first time in the Middle East; by building the first ship of these series, Iran has joined the major ship builders in the world.



### **Maritime Transport**

Located in an appropriate geographical position, the Islamic Republic of Iran enjoys good transit advantages. By expanding its transportation network and making safe and efficient connections, Iran can optimally use these advantages in order to increase its foreign exchange earnings and



optimally promote its strategic status in the region. The Persian Gulf located in the South of Iran encompasses major oil producing countries of the world, thus the region is considered as the world's oil choke point.



The Caspian Sea in the north of Iran is the most significant bridge between Iran, Russia, Kazakhstan, Turkmenistan, and Azerbaijan. Using its road and rail transportation industry, Iran can play a major role in conducting trade between these countries and the open seas.

Since connecting Central Asian and the Persian Gulf countries as well as establishing commercial ties between East Asian and European countries would be very economical through Iran, many countries are seeking to gain such European-Asian links via Iran.



In addition to transit advantages of Iran's international open waters, the country's vast water borders have also contributed to booming of domestic industries. A lot of opportunities are available in the marine sector, such as presence in the bunkering industry and construction of offshore drilling rigs, to name a couple among many. In order to make use of this especial opportunity, we need to take a systematic approach that considers eliminating the bottlenecks and highlights all dimensions of this opportunity simultaneously.

### **Offshore**

Having enormous oil and gas reservoirs in Iran, activities in the field of offshore industries were been started in 1965. Because of abundant oil and gas reservoirs in the Southern parts of the country and their easy exploitation, this field has been the main focus of offshore industries in recent years. One of the characteristics of the Southern part of the country, especially the Persian Gulf, is shallow areas that have a depth of 50 to 100 meters, and in this range of depth, patterned fixed platforms are the best and most economical alternative. Therefore in recent years, thanks to efforts of the country's domestic industries, vast activities have been undertaken in the field of constructing patterned platforms and installation technology; more than 140 of these platforms, in different sizes and designs, have been already utilized in the Persian Gulf. The most important companies active in the field of offshore industry and construction of marine platforms, pipelines and port equipment include SADRA, ISOICO, IOEC, GHORB NOOH, Offshore Industries Company (SAF), Iranian Offshore Oil Company (IOOC), and so on; of which SADRA, North Drilling Company, Khazar Oil Company, and other small firms work in the Caspian Sea. By performing big projects, these companies play a major role in supplying domestic needs, localizing construction, and utilization technologies. One of the most successful experiences in this field is construction of Amir Kabir semi-submersible platform in the Caspian Sea. This platform is one of the first experiences of Iranian companies in deep waters which promise a bright future in construction of submersible and semi-submersible platforms in Iran.

### **Ports**

According to studies from the Ports and Maritime Organization, Iran has a coastline of 4695 km in the mainland and 1095 km of coastline related to islands and rivers. These coastlines which are located in the Northern coasts of the Persian Gulf and Gulf of Oman and in the Southern cost of the Caspian Sea in the North make it possible for Iran to benefit from international marine transportation. At the moment, among 30 provinces in Iran; Gilan, Mazandaran, and Golestan provinces with access to the Caspian Sea in the North, and Khuzestan, Bushehr, Hormozgan, and Sistan & Baluchestan provinces with access to Persian Gulf and Gulf of Oman in the South are the



areas that provide marine transportation for international trade. It is important to mention that in the South, from port of Chabahar in the Southeast to port of Khorramshahr in the Southwest, coastlines make a great contribution to the international trade of the country via marine transportation. While in the East, West, and some parts of the North, it is possible to use other transportation methods such as rail, road, and pipeline transportation.

### **Marine Tourism**

Besides other natural, cultural, and political attractions, Iran has coastlines measuring more than 5700 km, beautiful islands, and an extraordinary ecosystem, making it potentially gifted for developing marine tourism.

Currently, a major part of the islands and coastal areas are governed as free trade zones and special economic zones which has paved the way for utilizing tourism capacities in the country.



## Fisheries

The abundance of aquatic life in the Northern and Southern seas of the country as well as the development of aquaculture industry in domestic waters, and the possibility of exploiting aquatic life in international waters have provided a bright perspective to provide as much marine protein resources as possible to supply the needs of the country.



In our country, the significant progress of fishing industry in recent years, the possibility of nurturing aquaculture throughout the country, the fish-bearing potential of lakes; reservoirs behind dams; ponds and rivers through releasing fish in them, and the possibility of extracting large amounts of fish all play a significant role in supplying a great portion of the protein needed by the country.



## **Education**

Marine programs in Iran universities include following disciplines and orientations:

1. Marine engineering with two orientations: shipbuilding engineering and ship engineering
2. Electronics engineering with the orientation of Marine Telecommunications
3. Sailing with the orientation of Deck Engineering
4. Management and Maritime Commissar
5. Management and maritime business with three orientations: Customs - Port and Shipping
6. Natural Resources and Environmental Engineering with one orientation: Fisheries
7. Fisheries with the orientation of reproducing aquaculture, aquatic ecology, fisheries product processing
8. Marine biology majoring sea animals, marine pollution, and marine ecology

# 10. Some of the Road, Housing & Urban Development Research Center Projects

## National Niksystem Plan

Niksystem Technology is the first integrated, efficient, and modern building system based on fully indigenous technology. Different types of houses required in the country are built by this technology. It has been designed according to National rules and regulations and along with applied principles and suggestions, it is intended to present new solutions for encouraging innovation in the building and construction system in the country. It should be noted that in spite of being a recent technology, Niksystem has been able to build more than 2000 units in various parts of the country, of which 940 units are already put into operation. Niksystem technology is also used for designing and building modular mosques and modular districts and sub-districts.

In 2010, a year after its introduction to industry, it won the title of “the best structure” in the first National Conference on structure and steel (the second conference on application of sub-strength steel in structure industry).

National Niksystem plan is designed as a result of three long term research projects including five complete building systems (for 1 to 5-floor housing), building system for rural house, temporary and quick-building house and exterior wall system with self-bearing panels. 6 types of Niksystem and 4 types of Nikpanel have already been patented. Modular and ergonomic design, industrialization, localization, creating innovation in building and construction system by means of current facilities, and conserving natural resources and national assets through a sustainable development plan are among the main features of Niksystem.

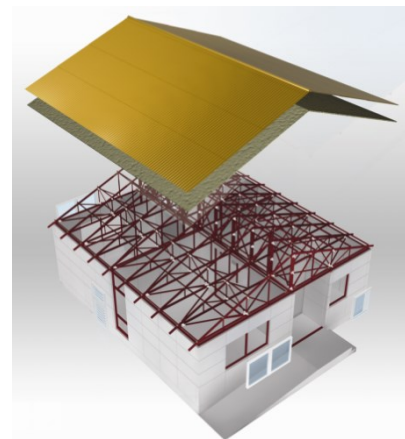

Niksystem 1



Niksystem 2



Niksystem 3 & 4 for 3-4 floor houses



Niksystem 5 for 5-floor houses

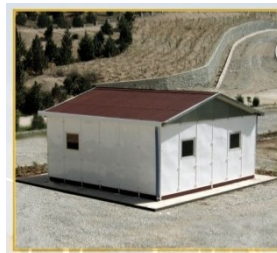

Niksystem for temporary and quick-building houses



Rural Niksystem

Niksystem technology for designing and building modular mosques

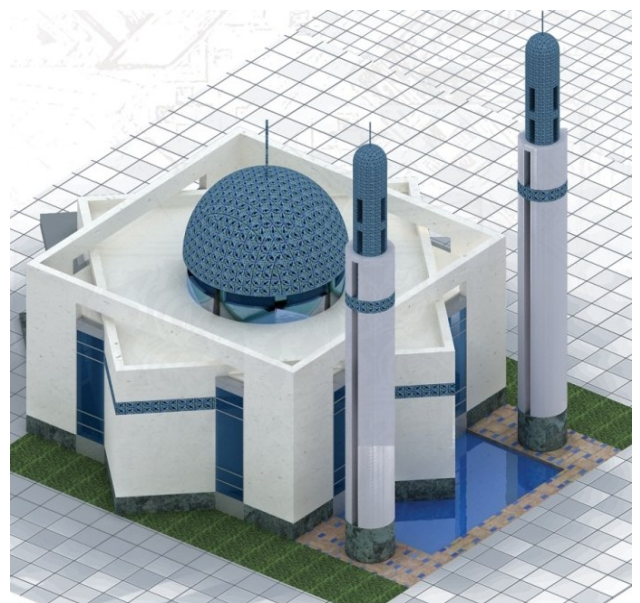
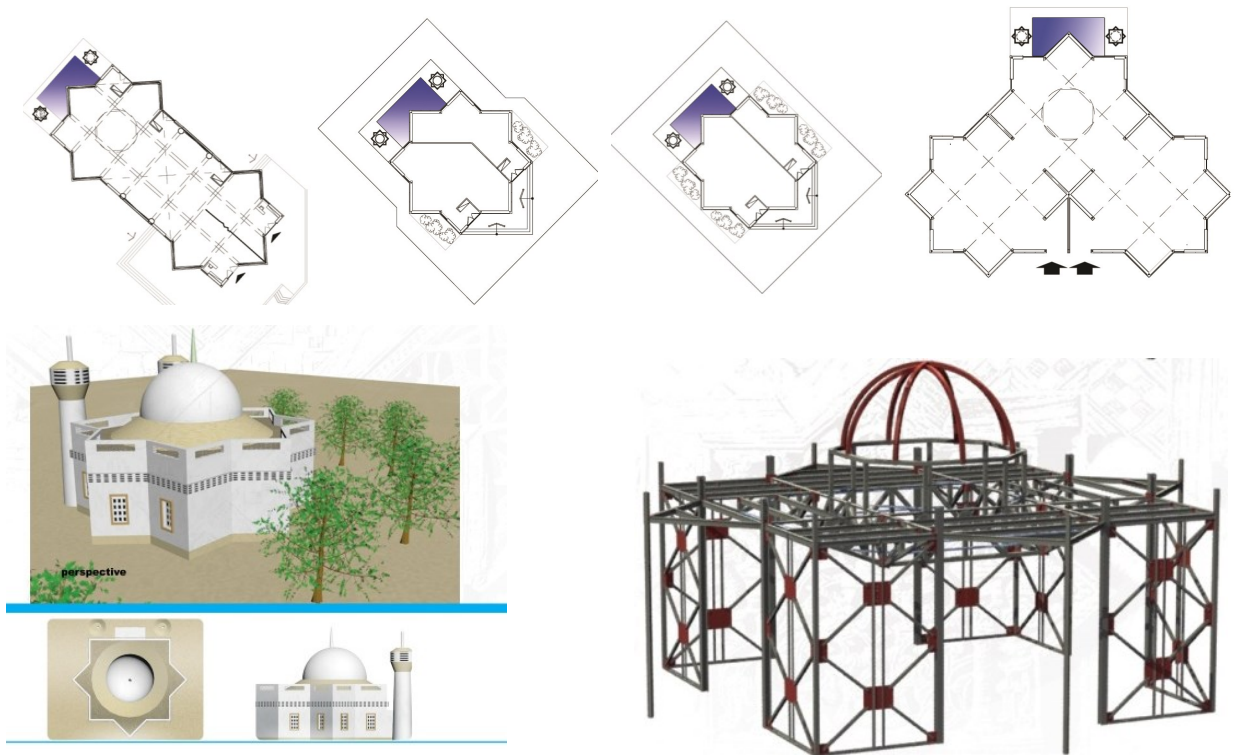



## New Generation of High Performance Concrete

Today, due to technical and economic advantages of high performance concretes, their application is growing rapidly so that they are commonly used in all types of prefabricated and residual components. Although high performance concretes have been used in constructing tall buildings and specific structures for many years, their construction cost is higher than that of the ordinary concrete and their implementation is associated with some limitations.

In order to solve these problems and expand their application, several measures have been undertaken and new generation of high performance concretes have been developed. The grade of cement for new generation of concretes is decreased and their properties have improved consequently. Some advantages of new generation of high performance concrete are as follows:

- Compared with the conventional concretes, and with an equal compressive strength, this type of concrete needs less cement;
- By relative decreasing of aggregate diameter, fine aggregates are effective in filling;
- Concrete compressibility is significantly increased. In this way, more compressibility created by means of vibrator and the air in spaces between aggregates is removed;
- These concretes have better ability to maintain water;
- Workshop costs for these concretes are less than other types of concretes.

## External Thermal Insulation Composite Systems (ETICS)

External Thermal Insulation Composite System is a kind of building facade that is used in external surfaces of walls or under the ceiling, either the existing ceiling or the new one for thermal insulation purposes. These systems are based on expanded polystyrene or mineral wool. They are composed of an insulation layer, a plated substrate layer,

a layer of mesh and a plated layer of the final facade. Increasing lifetime of the building (resistant against ultraviolet radiation and crack) and speed of construction, decreasing the weight of the building, energy saving during operation of the building, thermal comfort, and beauty are among the advantages of these systems. However, it should be noted that these systems should be reconstructed every 20-30 years and even 15 years in polluted cities.



### Producing Seismograph (seismometer)

In the 5<sup>th</sup> Development Plan, a great attention is devoted to developing seismograph network in the country and at least 3000 seismometers should be installed throughout the county until completion of this Plan. Using seismograph, one can measure seismic waves due to earth movement. Seismometer can be operated continuously or based on standard algorithms such as Level & STA/LTA. It records seismic waves of the ground based on predetermined units (g, m/sec/sec, cm/sec/sec ...).

Given the measures taken, this device supports many standard communication protocols (wired and wireless). So, one can easily connect to this device either conventionally or from long-distance across the country.

